

Front

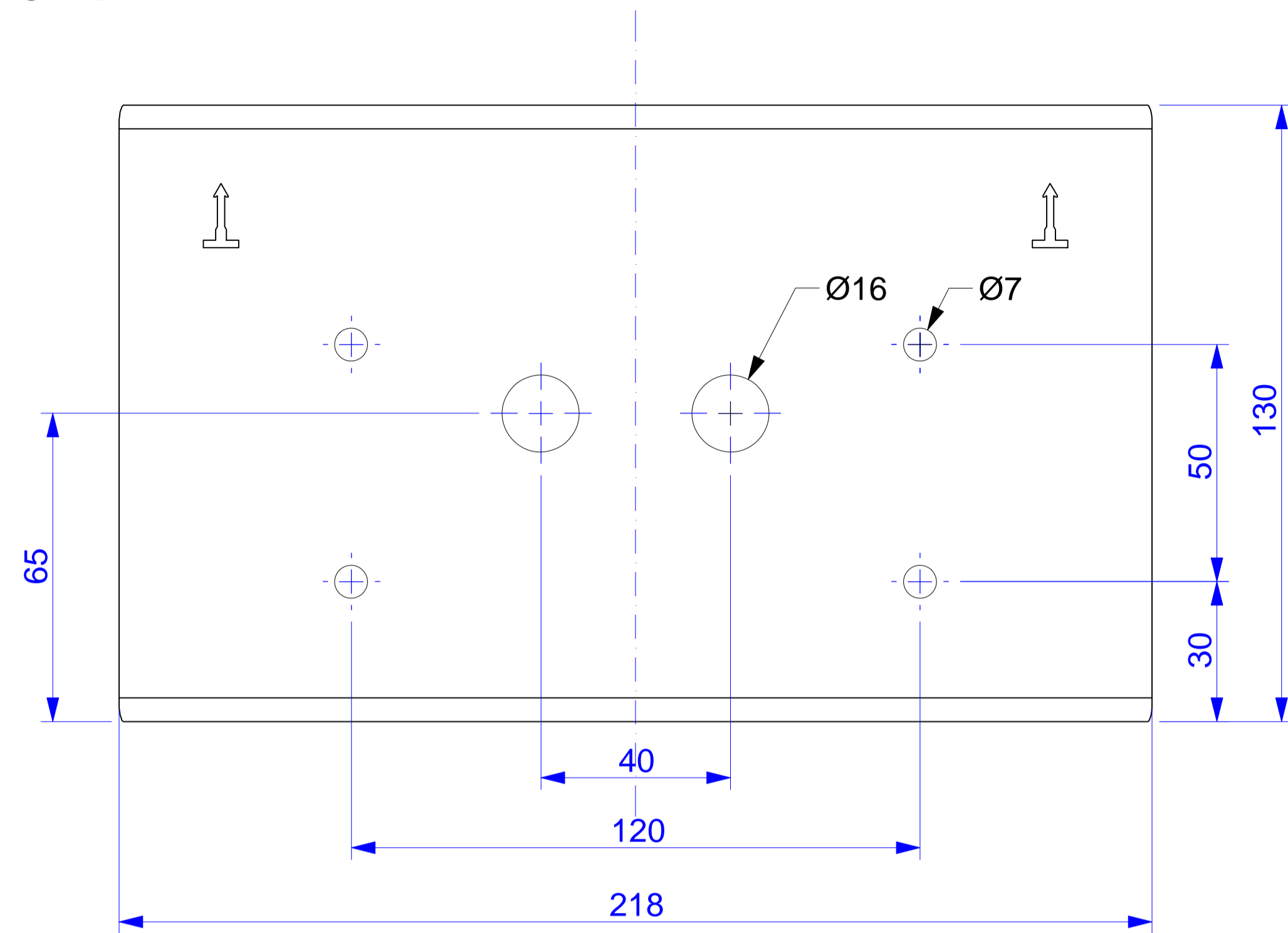

Side

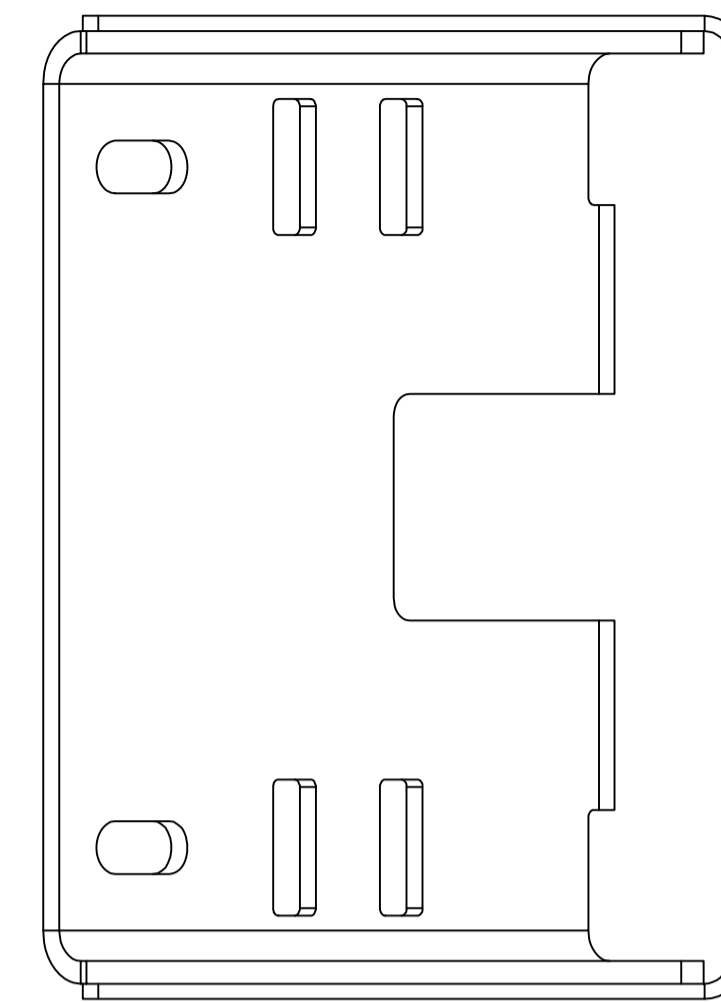

Back

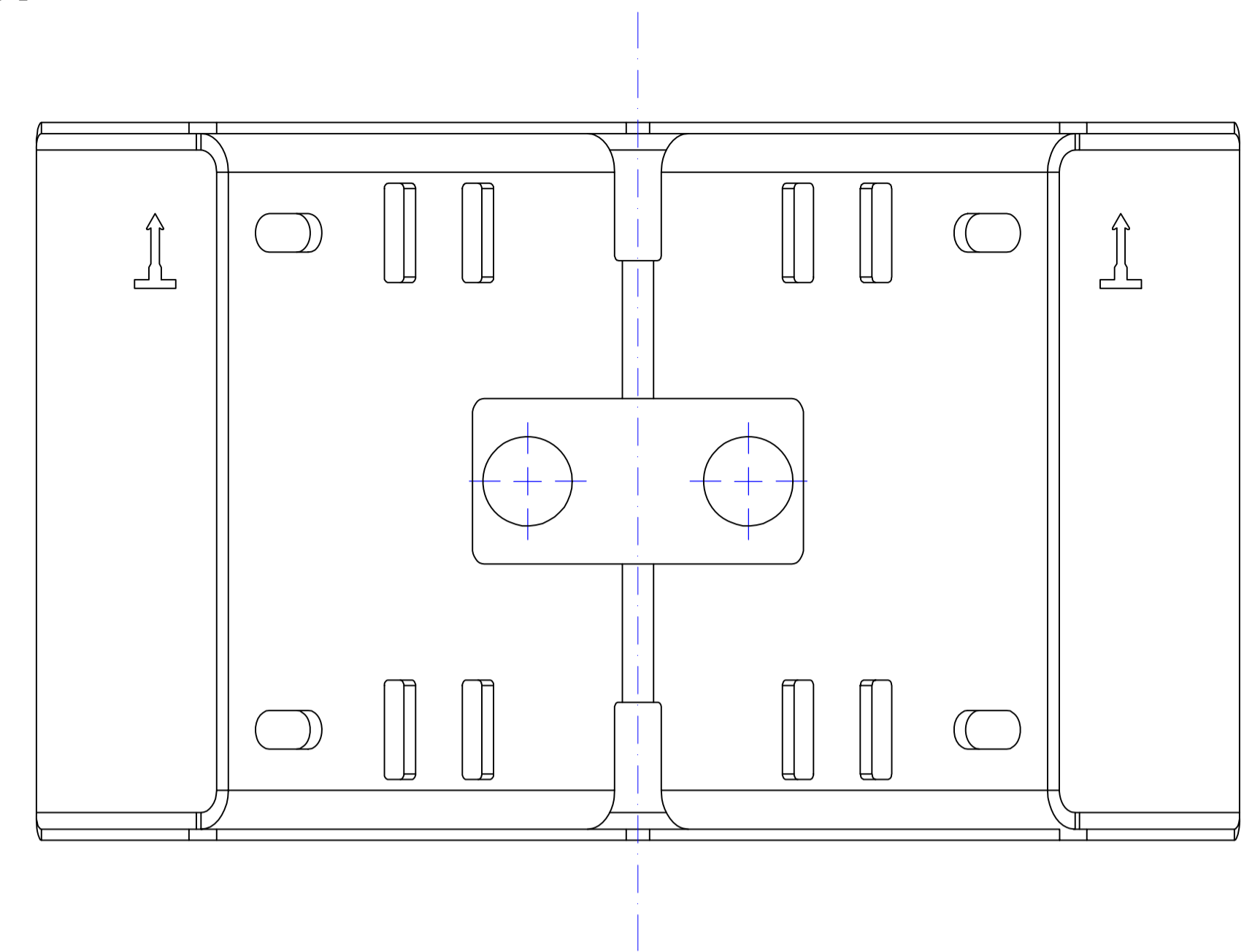

Top

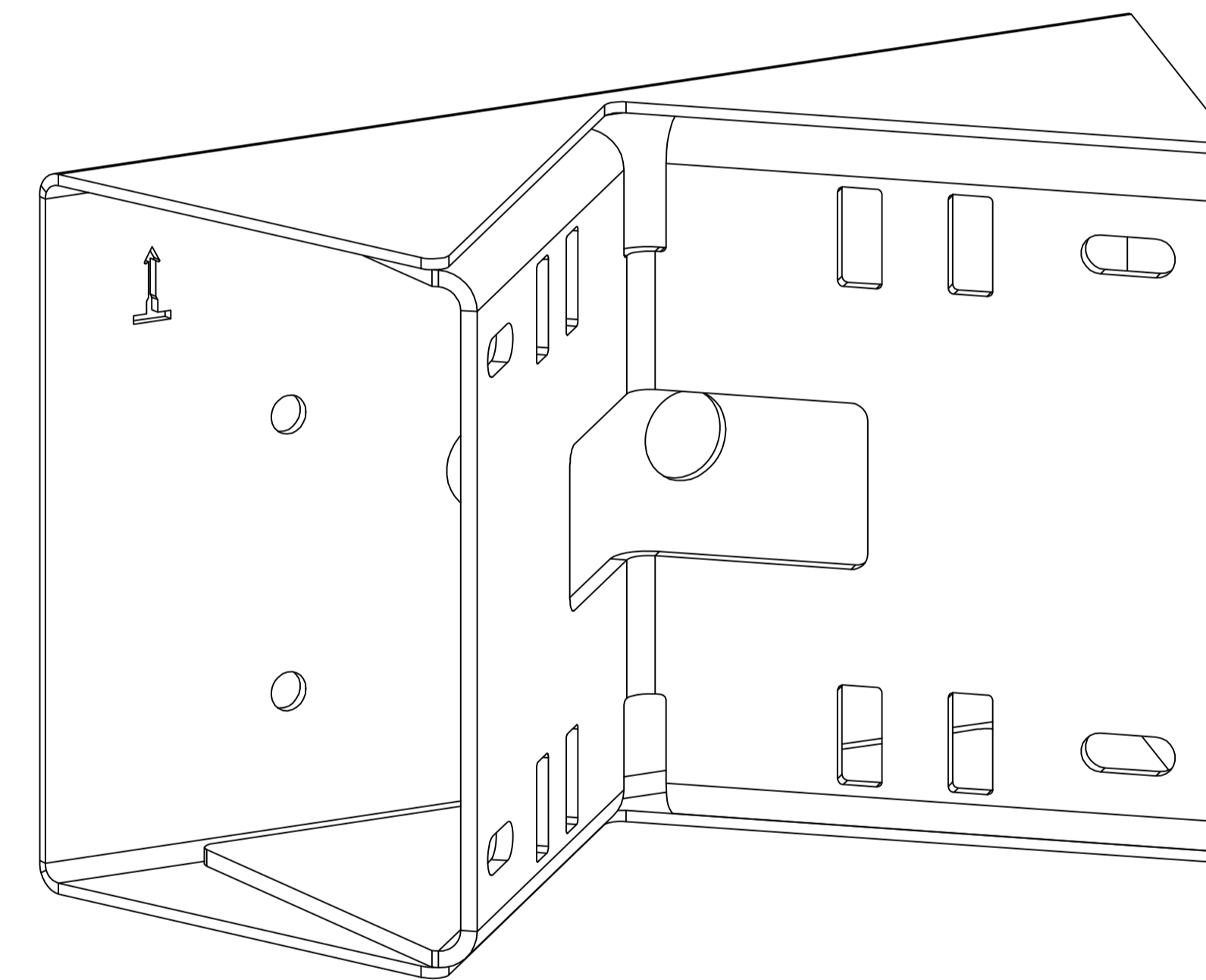
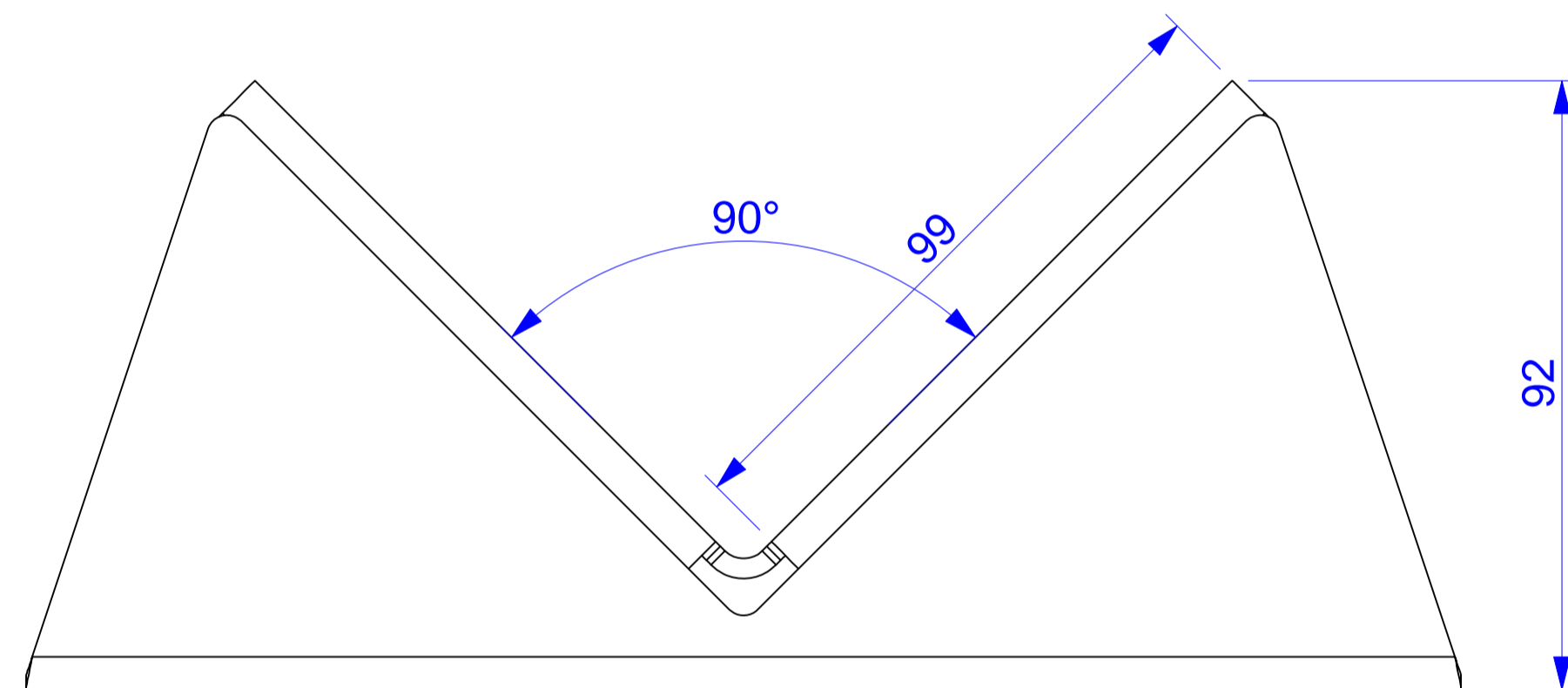

For internal use only. Technical specifications subject to change without notice. MOBOTIX does not assume responsibility for mistakes and recommends to verify measures and mechanical design with an actual product of the chosen MOBOTIX hardware. The reproduction, distribution and utilization of this document as well as the communication of its contents to others without express authorization is prohibited. Offenders will be held liable for the payment of damages. All rights reserved in the event of the grant of a patent, Utility model, design or trademark. No rights are transferred herewith.

All measures are in mm		Surface quality		Company	
				MOBOTIX AG	
	Name	Signature	Date	Product	
Drawn	SBe		13.07.17	Q2x Pole Mount	
Tested					
Approved					
Production					
Quality				Material	Drawing
					DIN A1
				Weight	Scale 1:1
					Page 1/1