

## Junction Box Installation

The MOBOTIX MOVE SpeedDome cameras can be mounted together with the Mx-M-SD-WMJB junction box and the Mx-M-SD-WM wall mount to allow easy cabling and installation of additional HW equipment such as PoE Injectors, lightning-protection etc. supplied by 3<sup>rd</sup>-party manufacturers.

### Junction Box Mx-M-SD-WMJB (for use with Wall Mount Mx-M-SD-WM)

136.0 x 256.0 x 256.0 mm; 4.15 kg.

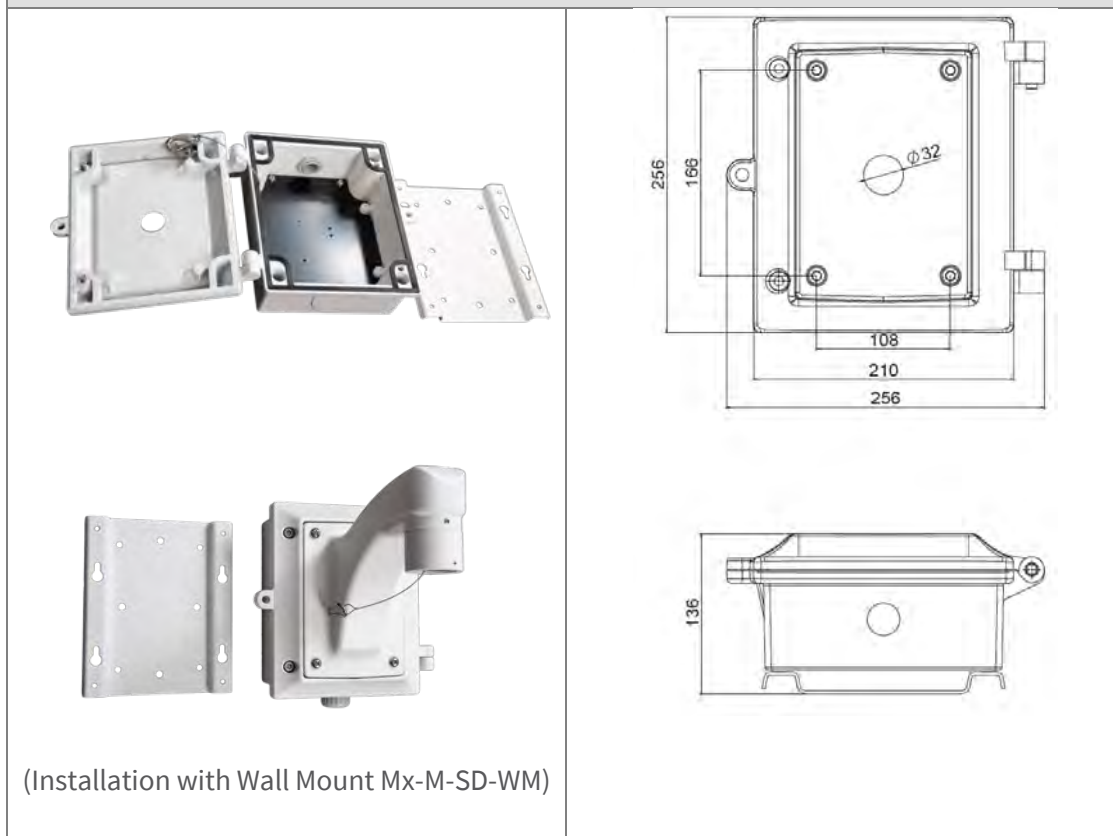

### Items Needed:

- Wall Mount Mx-M-SD-WM
- Power Cable (optional if SpeedDome is not PoE-powered)
- Ethernet Cable

### Tools Needed:

- Drill
- Screwdrivers (Allen, flat)

Follow the steps to fix the wall mount junction box and assemble the Wall Mount MX-M-SD-WM.

**STEP 1**

Drill a cable entry hole through the wall or equip a junction box side entry (top or bottom access) with mounted PG-Gland to recess the cables. Run the Ethernet cable and additional needed cabling such as power cable, alarm I/O or Audio I/O into the junction box.

**Step 2**

Install additional HW equipment needed and ensure secure fixation and cable wiring to prevent from electric shortcut.

**STEP 3**

Align the screw holes on the Wall mount installation plate with the 8 drilled holes and fix the installation plate to the wall with minimum four (8) suitable screws. Ensure firm fixation at wall to prevent mount from falling off.



**STEP 4**

Attach 4 matching screws to the junction box, which can be hooked into the mounting plate holes marked in below figure:

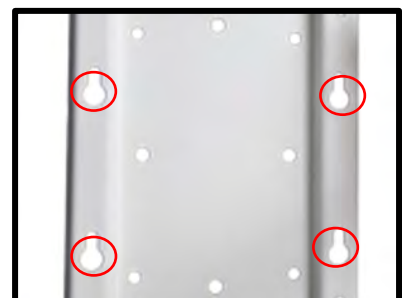

**STEP 5** Stabilize the construct by tightening the four marked screws below figure:

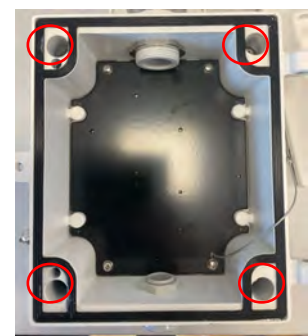

**STEP 6**

Feed cabling through required junction box cable entries from field cabling and interconnect with optional integrated components 7 parts such as surge protection or others..)

**STEP 7**

Assemble PG Gland at Junction-Box “Door” PG Gland entry and feed trough cabling (ethernet, Power, Alarm etc...)



NOTE: For the cable gland installation, please follow the steps below:

**Step (a):**

Pass the supplied thicker rubber ring through the cable gland



**Step (b):**

Loosen the thread-lock sealing nut from the cable gland body.



**Step (c):**

Insert the required cables, e.g., Ethernet cable, to the thread-lock sealing nut and the cable gland body from the bottom.



**Step (d):**

Twist the cable gland body a little bit back to the thread-lock sealing nut but not entirely tightened.



**STEP 7**

Continue with assembling the SpeedDome Wallmount Mx-M-SD-WM.



**Important:**

**This Junction box must only be used with Wall Mount Mx-M-SD-WM.** Ensure that all mounting screws are fixed firmly to prevent equipment to fall off and avoid injuries. We recommend checking the proper installation along annual maintenance intervals. In case of visible “damage”, please immediately replace component!