

# Quick Installation

## MOBOTIX S74

© 2026 MOBOTIX AG



BeyondHumanVision

**MOBOTIX**

V2.72, 4/21/2026, Order Code: Mx-S74A

# Table of Contents

---

<b>Table of Contents</b> .....	<b>2</b>
<b>Before You Start</b> .....	<b>5</b>
Support .....	6
MOBOTIX Support .....	6
MOBOTIX eCampus .....	6
MOBOTIX Community .....	6
Safety Notes .....	7
Legal Notes .....	8
<b>Notes on System Security</b> .....	<b>11</b>
<b>Drilling Template</b> .....	<b>13</b>
Drilling Template PDF .....	14
<b>Scope of Delivery</b> .....	<b>15</b>
MOBOTIX S74: Scope of Delivery .....	16
Mounting Supplies: Scope of Delivery .....	17
PTMount: Scope of Delivery .....	18
PTMount Multisense: Scope of Delivery .....	19
PTMount-Thermal: Scope of Delivery .....	20
<b>Technical Specifications</b> .....	<b>21</b>
Hardware .....	22
Power Consumption .....	23
Image and Video Properties .....	24
General Software Features .....	25
Video Analysis .....	26
Video Management Software .....	26
Sensor Modules .....	27
Dimensions of Sensor Modules .....	27
Supported Image Sensor Modules .....	27
Supported Thermal Sensor Modules .....	28
Features Thermal Image Sensors – B-Models .....	30
Features Thermal Image Sensors – C-Models .....	31
Features ECO Thermal Image Sensor .....	32
Functional Modules .....	33
Interface Slide-in Boards .....	34
S74 Network Slide-in Board with RJ45 socket .....	34
S74 Network Slide-in Board with LSA terminal .....	34
S74 IO Slide in Board .....	34
S74 Network Slide-in Board with RJ45 and VDC power supply - A .....	35
S74 Network Slide-in Board with RJ45 and VDC power supply - B .....	36
Dimensions .....	36
PTMount – Dimensions .....	37
PTMount-Thermal – Dimensions .....	37

---

<b>Mounting</b> .....	<b>39</b>
Before Mounting the Camera .....	40
Installing Sensor Modules .....	42
Preparing the Sensor Modules .....	42
Installing Sensor Module without Mounts .....	43
Installing Sensor Module with PTMount .....	44
Installing Sensor Module PTMount-Thermal .....	48
Installing Slide-in Boards .....	51
Installing the S74 Network Slide-in Board with RJ45 socket .....	51
Installing the S74 Network Slide-in Board with LSA terminal .....	52
Installing the S74 Network Slide-in Board with RJ45 and VDC power supply .....	57
Installing the S74 IO Slide in Board .....	59
Mounting the Camera .....	65
Connecting Module Cables to the Camera .....	66
Sensor Module Combinations .....	68
Connecting the Camera to the Network .....	69
<b>Operating the Camera</b> .....	<b>71</b>
Getting Started .....	71
LED states .....	72
Boot Options of the Camera .....	73
Initial Camera Setup .....	75
Check the Preconditions .....	75
Access the Camera .....	76
Find the "Real" IP Address of the Camera .....	79
Network Settings on the Camera in MxMC .....	79
Focusing the TELE 15° Sensor Module .....	81
<b>Camera Software in the Browser</b> .....	<b>85</b>
Access the Camera in the Web Browser .....	86
Basic Settings .....	87
Configuring Sensor Modules .....	88
<b>Maintenance</b> .....	<b>91</b>
Cleaning the Camera and Lenses .....	92

---



## Before You Start

This section contains the following information:

<b>Support</b> .....	<b>6</b>
<b>Safety Notes</b> .....	<b>7</b>
<b>Legal Notes</b> .....	<b>8</b>

# Support

## MOBOTIX Support

If you need technical support, please contact your MOBOTIX dealer. If your dealer cannot help you, he will contact the support channel to get an answer for you as quickly as possible.

If you have internet access, you can open the MOBOTIX help desk to find additional information and software updates.

Please visit [www.mobotix.com](http://www.mobotix.com) > [Support](#) > [Help Desk](#).



## MOBOTIX eCampus

The MOBOTIX eCampus is a complete e-learning platform. It lets you decide when and where you want to view and process your training seminar content. Simply open the site in your browser and select the desired training seminar.

Please visit [www.mobotix.com/ecampus-mobotix](http://www.mobotix.com/ecampus-mobotix).



## MOBOTIX Community

The MOBOTIX community is another valuable source of information. MOBOTIX staff and other users are sharing their information, and so can you.

Please visit [community.mobotix.com](http://community.mobotix.com).



## Safety Notes

- This product must be installed by qualified personnel and the installation should conform to all local codes.
- This product must not be used in locations exposed to the dangers of explosion.
- Do not use this product in a dusty environment.
- Protect this product from moisture or water entering the housing.
- Install this product as outlined in this document. A faulty installation can damage the product!
- Do not replace batteries of the device. If a battery is replaced by an incorrect type, the battery can explode.
- External power supplies must comply with the Limited Power Source (LPS) requirements and share the same power specifications with the camera.
- To comply with the requirements of EN 50130-4 regarding the power supply of alarm systems for 24/7 operation, it is highly recommended to use an uninterruptible power supply (UPS) for backing up the power supply of this product.

# Legal Notes

## Copyright Notice!

© 2020 MOBOTIX AG. All rights reserved.

This document and its contents are the property of MOBOTIX AG and are protected by applicable copyright laws. Any reproduction, distribution, modification, or use of this document, in whole or in part, without prior written permission of MOBOTIX AG is strictly prohibited.

All product names, trademarks, logos, and brands referenced in this document are the property of their respective owners. These may include, but are not limited to, trademarks and certification marks of third-party organizations such as FM Approvals. The use of such marks is for identification and informational purposes only and does not imply any affiliation with or endorsement by the respective trademark owners. MOBOTIX AG acknowledges the rights of all trademark holders and makes no claim to trademarks owned by third parties.

## Special Export Regulations!

Cameras with thermal image sensors ("thermal cameras") are subject to the special export regulations of the U.S. and including the ITAR (International Traffic in Arms Regulation):

- According to current U.S. export control regulations, including the International Traffic in Arms Regulations (ITAR) and the Export Administration Regulations (EAR), thermal imaging cameras, sensors, and related components may be subject to export restrictions or licensing requirements depending on their technical characteristics and classification.
- Exports, re-exports, or transfers to comprehensively embargoed or sanctioned destinations are generally prohibited unless authorized by the relevant U.S. authorities. As of now, this includes, in particular: Crimea, Donetsk and Luhansk regions of Ukraine, Cuba, Iran, North Korea, and Syria.
- In addition, exports to certain countries such as Russia and Belarus are subject to extensive restrictions and, for many controlled items, are effectively prohibited.
- Furthermore, exports to any persons, entities, or organizations listed on U.S. government restricted party lists are prohibited. These include, but are not limited to, the Denied Persons List (DPL), the Entity List, and the Specially Designated Nationals (SDN) List, as maintained by the U.S. Department of Commerce and the U.S. Department of the Treasury.
- All exports must be reviewed on a case-by-case basis to ensure compliance with applicable U.S. export control laws and regulations.

- Under no circumstances must the camera itself or its thermal image sensors be used in the design, the development or in the production of nuclear, biological or chemical weapons or in the weapons themselves.

## Legal Aspects of Video and Sound Recording

You must comply with all data protection regulations for video and sound monitoring when using MOBOTIX AG products. Depending on national laws and the installation location of the cameras, the recording of video and sound data may be subject to special documentation or it may be prohibited. All users of MOBOTIX products are therefore required to familiarize themselves with all applicable regulations and to comply with these laws. MOBOTIX AG is not liable for any illegal use of its products.

## Declaration of Conformity

The products of MOBOTIX AG are certified according to the applicable regulations of the EC and other countries. You can find the declarations of conformity for the products of MOBOTIX AG on [www.mobotix.com](http://www.mobotix.com) under **Support > Download Center > Marketing & Documentation > Certificates & Declarations of Conformity**.

## RoHS Declaration

The products of MOBOTIX AG are in full compliance with European Unions Restrictions of the Use of Certain Hazardous Substances in Electrical and Electronic Equipment (RoHS Directive 2011/65/EU) as far as they are subject to these regulations (for the RoHS Declaration of MOBOTIX, please see [www.mobotix.com](http://www.mobotix.com), **Support > Download Center > Marketing & Documentation > Brochures & Guides > Certificates**).

## Disposal

Electrical and electronic products contain many valuable materials. For this reason, we recommend that you dispose of MOBOTIX products at the end of their service life in accordance with all legal requirements and regulations (or deposit these products at a municipal collection center). MOBOTIX products must not be disposed of in household waste! If the product contains a battery, please dispose of the battery separately (the corresponding product manuals contain specific directions if the product contains a battery).

## Disclaimer

MOBOTIX AG does not assume any responsibility for damages, which are the result of improper use or failure to comply to the manuals or the applicable rules and regulations. Our General Terms and Conditions apply. You can download the current version of the **General Terms and Conditions** from our website at [www.mobotix.com](http://www.mobotix.com) by clicking on the corresponding link at the bottom of every page.

## Before You Start

### Legal Notes

---

It is the User's responsibility to comply with all applicable local, state, national and foreign laws, rules, treaties and regulations in connection with the use of the Software and Product, including those related to data privacy, the Health Insurance Portability and Accountability Act of 1996 (HIPPA), international communications and the transmission of technical or personal data.

## FCC Disclaimer

This equipment has been tested and found to comply with the limits for a Class A digital device, pursuant to part 15 of the FCC Rules. These limits are designed to provide reasonable protection against harmful interference when the equipment is operated in a commercial environment. This equipment generates, uses, and can radiate radio frequency energy and, if not installed and used in accordance with the instruction manual, may cause harmful interference to radio communications. Operation of this equipment in a residential area is likely to cause harmful interference in which case the user will be required to correct the interference at his own expense.

# Notes on System Security

To protect the camera against security risks in data technology, the following measures are recommended after the installation has been completed:

MxManagementCenter:

- Menu **View > Wizards & Tools > Secure System:**
  - **Change camera factory default password:** ✓
  - **Enable encrypted HTTPS:** ✓
  - **Disable public access:** ✓
  - **User Management** (for all users):
    - **Force Complex Password:** ✓
    - **Log out on Inactivity:** After 5 min

User interface of the camera in the browser:

- **Admin Menu > Network Setup > Web Server:**
  - **Enable MxWeb:** –
  - **Enable intrusion detection:** ✓
  - **Notification threshold:** 10
  - **Timeout:** 60 minutes
  - **Block IP Address:** ✓

For more information on this new feature, please read the «Cyber Protection Guide» on [www.mobotix.com](http://www.mobotix.com) (under Support > Download Center > Documentation > Brochures & Guides > Cyber Security).



## Drilling Template

Open this file in a PDF viewer (Adobe Reader or similar) and print the file **without scaling (original size)**.

**NOTE!** Drilling template: [www.mobotix.com](http://www.mobotix.com) > [Support](#) > [Download Center](#) > [Marketing & Documentation](#) > [Drilling Templates](#).

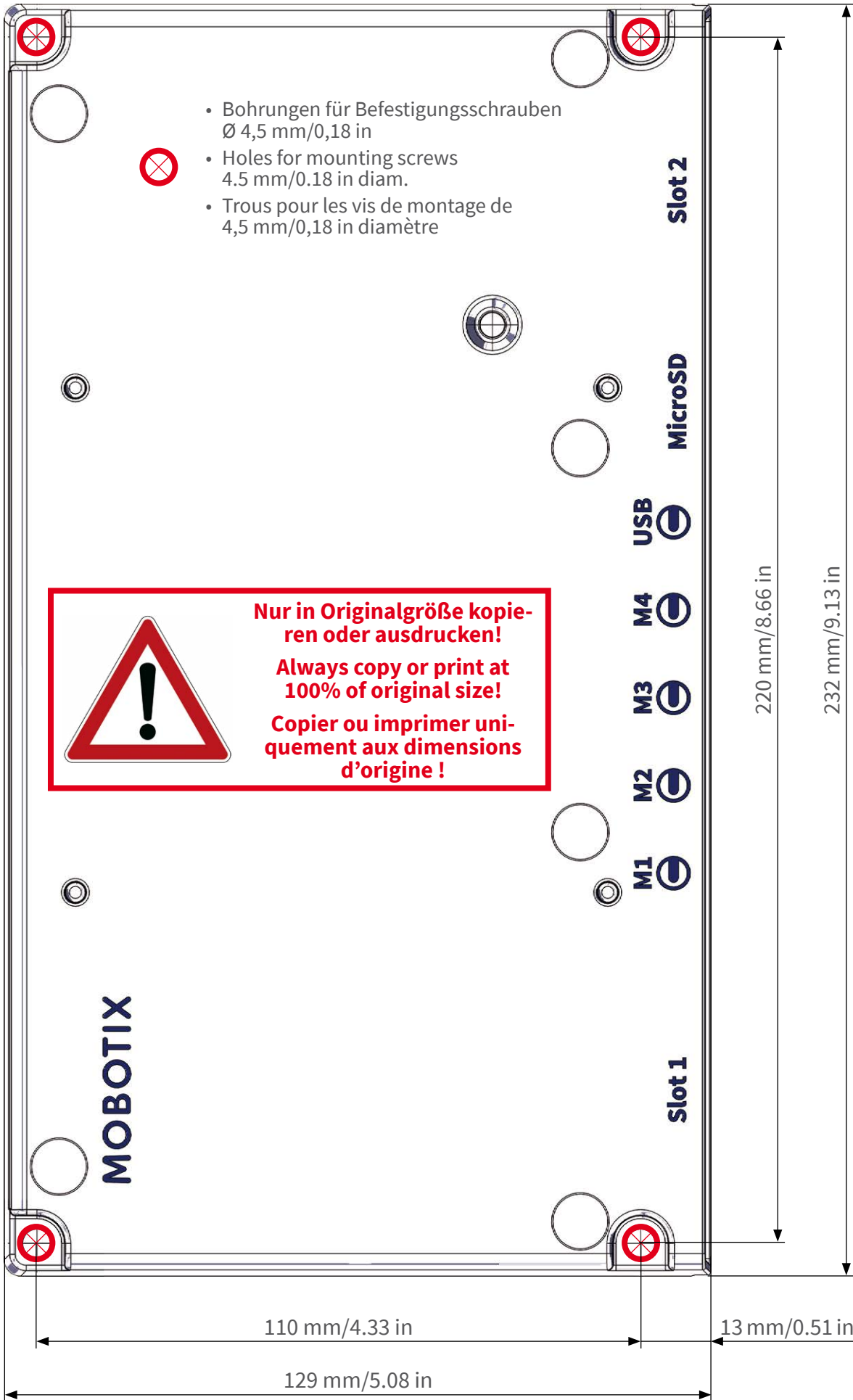

MOBOTIX est une marque déposée de MOBOTIX AG en Union Européenne, aux États-Unis et dans d'autres pays. Susceptible de modification sans préavis. MOBOTIX ne se tient responsable d'aucune erreur technique ou de rédaction, ni d'omission dans le présent document. Tous droits réservés. © MOBOTIX AG 2017  
[www.mobotix.com](http://www.mobotix.com) > Support > Centre de téléchargement > Documentation > Certificats & Déclarations de conformité

MOBOTIX is a trademark of MOBOTIX AG registered in the European Union, the U.S.A., and in other countries. Subject to change without notice. MOBOTIX do not assume any liability for technical or editorial errors or omissions contained herein. All rights reserved. © MOBOTIX AG 2017  
[www.mobotix.com](http://www.mobotix.com) > Support > Download Center > Documentation > Certificates & Declarations of Conformity

MOBOTIX ist ein eingetragenes Warenzeichen der MOBOTIX AG in der Europäischen Union, den USA und in anderen Ländern. Änderungen vorbehalten. MOBOTIX übernimmt keine Haftung für technische Fehler, Druckfehler oder Auslassungen. Alle Rechte vorbehalten. © MOBOTIX AG 2017  
[www.mobotix.com](http://www.mobotix.com) > Support > Download Center > Dokumentation > Zertifikate & Konformitätserklärungen



## Scope of Delivery

This section contains the following information:

<b>MOBOTIX S74: Scope of Delivery</b> .....	<b>16</b>
<b>Mounting Supplies: Scope of Delivery</b> .....	<b>17</b>
<b>PTMount: Scope of Delivery</b> .....	<b>18</b>
<b>PTMount-Thermal: Scope of Delivery</b> .....	<b>20</b>

# MOBOTIX S74: Scope of Delivery



## Scope of delivery MOBOTIX S74 Body

Item	Count	Description
1.0	1	MOBOTIX S74, complete
1.1	1	Mounting supplies (see <a href="#">Mounting Supplies: Scope of Delivery, p. 17</a> )
1.2	1	SD card 8 GB (installed)
1.3	1	Important Safety Information

---

# Mounting Supplies: Scope of Delivery

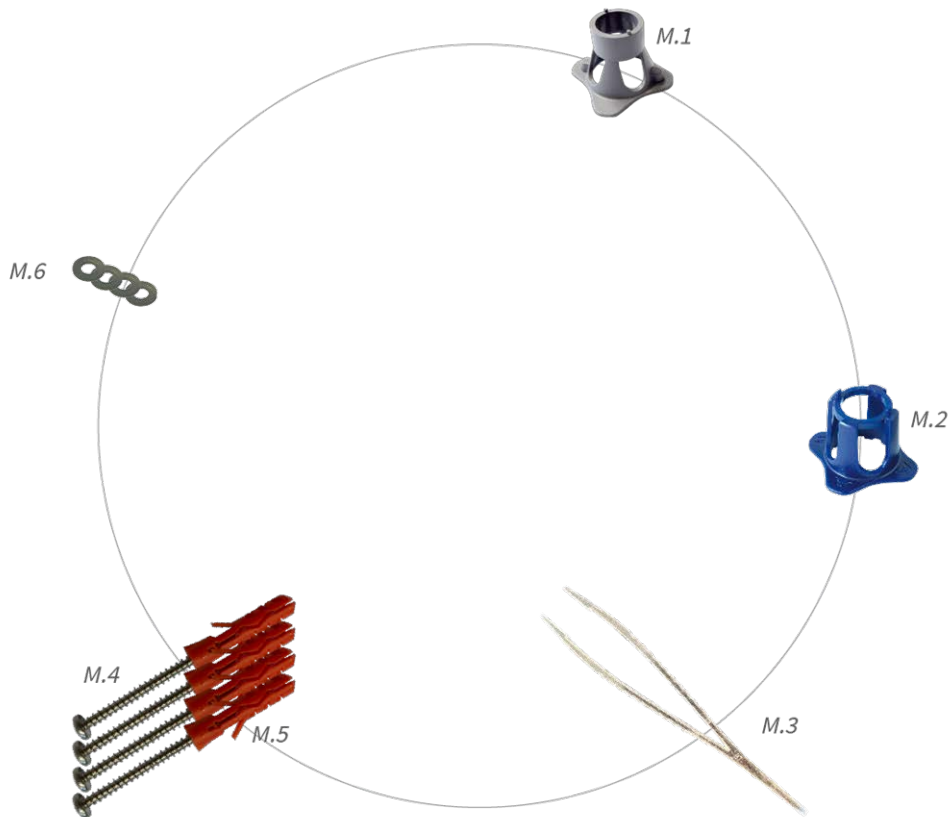

## Scope of Delivery MOBOTIX S74 Mounting Supplies

Item	Count	Description
M.1	1	Module wrench
M.2	1	Lens wrench
M.3	1	Tweezers
M.4	4	Wood screw 4.5x60 mm
M.5	4	Dowel S8
M.6	4	Washer

# PTMount: Scope of Delivery



## Scope of Delivery PTMount

Item	Count	Description
PM.1	1	Sphere with rotating insert (installed)
PM.2	1	Foot (installed)
PM.3	1	Base plate (installed)
PM.4	1	Swivel ring (installed)
PM.5	1	Sealing
PM.6	4	Washer Ø 4.3 mm, stainless steel
PM.7	4	Wood screw 4x40 mm, stainless steel
PM.8	4	Screw anchor S6
PM.9	1	Allen wrench 2.5 mm

## PTMount Multisense: Scope of Delivery

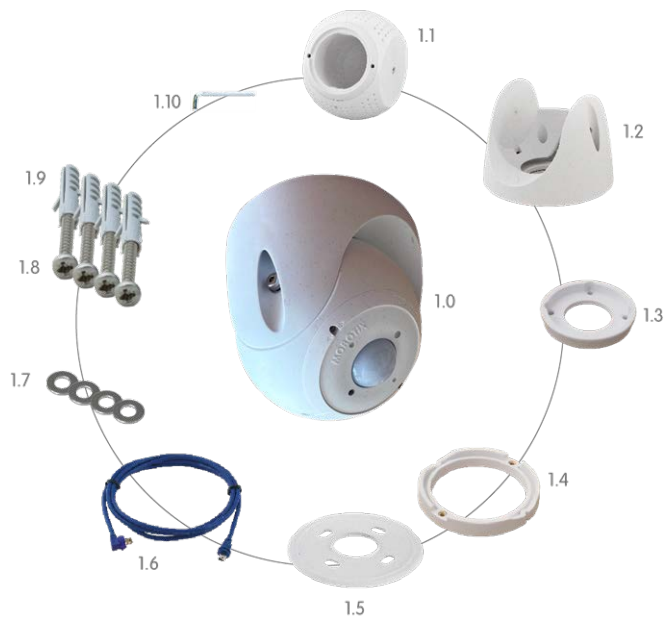

### Scope of Delivery PTMount Multisense

Item	Count	Description
PM 1.0	1	PT-Mount with Multisense module (completely pre-mounted)
PM 1.1	1	Sphere with Multisense module (installed)
PM 1.2	1	Foot (installed)
PM 1.3	1	Base plate (installed)
PM 1.4	1	Swivel ring (installed)
PM 1.5	1	Sealing
PM 1.6	1	Sensor cable 3 m/9.9 ft (installed)
PM 1.7	4	Washer Ø 4.3 mm, stainless steel
PM 1.8	4	Wood screw 4x40 mm, stainless steel
PM 1.9	4	Screw anchor S6
PM 1.10	1	Allen wrench 2.5 mm

# PTMount-Thermal: Scope of Delivery



## Scope of Delivery PTMount-Thermal

Item	Count	Description
------	-------	-------------

PM-T.1	1	Sphere with rotating Thermal/Thermal-TR sensor module (installed)
--------	---	---

PM-T.2	1	Foot (installed)
--------	---	------------------

PM-T.3	1	Base plate (installed)
--------	---	------------------------

PM-T.4	1	Swivel ring (installed)
--------	---	-------------------------

PM-T.5	1	Sealing
--------	---	---------

PM-T.6	4	Sensor cable 2 m/6.6 ft (installed)
--------	---	-------------------------------------

PM-T.7	4	Washer Ø 4.3 mm, stainless steel
--------	---	----------------------------------

PM-T.8	4	Wood screw 4x40 mm, stainless steel
--------	---	-------------------------------------

PM-T.9	1	Screw anchor S6
--------	---	-----------------

PM-T.10	1	Allen wrench 2 mm
---------	---	-------------------

PM-T.11	1	Allen wrench 2.5 mm
---------	---	---------------------

## Technical Specifications

This section contains the following information:

<b>Hardware</b> .....	<b>22</b>
<b>Image and Video Properties</b> .....	<b>24</b>
<b>General Software Features</b> .....	<b>25</b>
<b>Video Analysis</b> .....	<b>26</b>
<b>Video Management Software</b> .....	<b>26</b>
<b>Sensor Modules</b> .....	<b>27</b>
<b>Functional Modules</b> .....	<b>33</b>
<b>Interface Slide-in Boards</b> .....	<b>34</b>
<b>Dimensions</b> .....	<b>36</b>

# Hardware

Feature	Properties
Image sensor (color or B&W sensor)	Up to 4K UHD 3840x2160, 16:9, 1/1,8"
Light sensitivity	<ul style="list-style-type: none"> <li>■ Color sensor (day): 0,1 lx @ 1/60s; 0,005 lx @ 1s</li> <li>■ BW sensor (night): 0,02 lx @ 1/60s; 0,001 lx @ 1s</li> </ul>
Exposure control	Manual and automatic mode 1 s to 1/16,000 s
IK protection class	IK10 (housing)
IP / NEMA protection class	IP66 / NEMA 4X
Operating temperature range	-40 to 65 °C/-40 to 149 °F
Min. cold start temperature	-30 °C/-22 °F
Relative Humidity	95 % non-condensing
Internal DVR Storage	Internal microSD card (SDHC/SDXC), 8 GB out-of-the-box, max. 2 TB.
I/Os	<a href="#">S74 IO Slide in Board, p. 34</a> required
Microphone/Speaker	<a href="#">S74 IO Slide in Board, p. 34</a> required
Passive infra-red sensor (PIR)	Available with functional module, max. 4.5 Watt (see <a href="#">Functional Modules, p. 33</a> )
Infra-red illumination	Three functional modules for wide-angle, standard, and tele lenses
Range of infra-red illumination	Up to 30 m/100 ft (may be more depending on scene)
Max. power consumption	<ul style="list-style-type: none"> <li>■ Max. 25 W/521 mA at 48 V</li> <li>■ Max. 25 W/1042 mA at 24 V</li> </ul>
Electrical surge protection	<a href="#">S74 Network Slide-in Board with LSA terminal, p. 34</a> or <a href="#">S74 Network Slide-in Board with RJ45 and VDC power supply - A , p. 35</a> required
PoE standard	PoE Plus (802.3at-2009)/Class 4 (Network Slide-in Board required. See <a href="#">Interface Slide-in Boards, p. 34</a> )
Interfaces	4 sensor / functional modules USB-C 2 Slots for slide in boards (Network, IOs etc.)

Feature	Properties
Mounting Options	Wall-mountable
Dimensions (height x width x depth)	36 x 232 x 110 mm
Weight without sensor modules	1.130g
Housing	Aluminum, PBT-30GF
Standard accessories	See <a href="#">MOBOTIX S74: Scope of Delivery, p. 16</a>
Detailed technical documentation	<a href="http://www.mobotix.com">www.mobotix.com</a> > <a href="#">Services</a> > <a href="#">Download Center</a> > <a href="#">Marketing &amp; Documentation</a>
MTBF	80,000 hours
Certificates	EN 50121-4, EN 55032, EN 55035, EN 61000-6-1, EN 61000-6-2, EN 61000-6-3, EN 61000-6-4, EN 62368-1, EN 63000, AS/NZS CISPR32, 47 CFR Part 15b, NRTL
Protocols	DHCP (client and server), DNS, ICMP, IGMP v3, IPv4, IPv6, HTTP, HTTPS, FTP, FTPS, MQTT, NFS, NTP (client and server), RTP, RTCP, RTSP, SFTP, SIP (client and server), SMB/CIFS, SNMP, SMTP, SSL/TLS 1.3, TCP, UDP, VLAN, VPN, Zero-conf/mDNS
Manufacturer warranty	5 years

## Power Consumption

System	Modules	Average Power Consumption	Max. Power Consumption
S74 - Body	Body only	<ul style="list-style-type: none"> <li>■ 8.1 W/169 mA at 48 V</li> <li>■ 8.1 W/337 mA at 24 V</li> </ul>	
S74 - Audio, no Video	Audio	<ul style="list-style-type: none"> <li>■ 8.1 W/169 mA at 48 V</li> <li>■ 8.1 W/337 mA at 24 V</li> </ul>	<ul style="list-style-type: none"> <li>■ Max. 25 W/521 mA at 48 V</li> <li>■ Max. 25 W/1042 mA at 24 V</li> </ul>
S74 - 4K, 12MP, IR, WL, Audio	Audio: PCB + Module M1: 4K Day/Night DN050 M2: IR 850nm wide-angle M3: 12MP Day/Night DN016	<ul style="list-style-type: none"> <li>■ 19.5 W/406 mA at 48 V</li> <li>■ 19.5 W/813 mA at 24 V</li> </ul>	

## Technical Specifications

### Image and Video Properties

System	Modules	Average Power Consumption	Max. Power Consumption
S74 - 4K, Thermal, IR, WL, Audio	Audio: PCB + Module M1: 4K Day/Night DN050 M2: IR 850nm wide-angle M3: Thermal Image Sensor 640R080 M4: White Light 5700K wide-angle	<ul style="list-style-type: none"><li>20.9 W/435 mA at 48 V</li><li>20.9 W/871 mA at 24 V</li></ul>	
S74 - Thermal, Multisense, WL, Audio	Audio: PCB + Module M1: 4K Day/Night DN050 M2: Multisense M3: Thermal Image Sensor 640R080 M4: White Light 5700K wide-angle	<ul style="list-style-type: none"><li>16.5 W/344 mA at 48 V</li><li>16.5 W/688 mA at 24 V</li></ul>	

## Image and Video Properties

Feature	Properties
Available video codecs	<ul style="list-style-type: none"><li>H.264, H.265</li><li>MxPEG+</li><li>MJPEG</li></ul>
Image resolutions	VGA 640x360, XGA 1024x576, HD 1280x720, FullHD 1920x1080, QHD 2560x1440, 4K UHD 3840x2160
Multi streaming	H.264, H.265 with triple streaming
Multicast stream via RTSP	Yes
Max. image resolution H.264	<ul style="list-style-type: none"><li>One sensor: 4K UHD, 3840x2160 (8MP)</li><li>Both sensors (dual image): 2x 4K UHD, 7680x2160 (16MP)</li></ul>
Max. frame rate	MxPEG: 20@4K, H.264: 30@4K, H.265: 30@4K

# General Software Features

Feature	Properties
WDR	Up to 120 dB
Software features	<ul style="list-style-type: none"> <li>▪ H.264, H.265 Multistreaming</li> <li>▪ Multicast stream via RTSP</li> <li>▪ Digital pan, tilt, zoom/vPTZ (up to 8x zoom)</li> <li>▪ Genetec protocol integration</li> <li>▪ Programmable exposure zones</li> <li>▪ Snapshot recording (pre/post-alarm images)</li> <li>▪ Continuous recording</li> <li>▪ Event recording</li> <li>▪ Time-controlled flexible event logic</li> <li>▪ Weekly schedules for recordings and actions</li> <li>▪ Event video and image transfer via FTP and email</li> <li>▪ Playback and QuadView via web browser</li> <li>▪ Animated logos on the image</li> <li>▪ Master/Slave functionality</li> <li>▪ Privacy zone scheduling</li> <li>▪ Remote alarm notification (network message)</li> <li>▪ Programming interface (HTTP API)</li> <li>▪ MxMessageSystem</li> </ul>
ONVIF compatibility	Profile G, S, T, (M with later firmware release)
Master/Slave functionality	Yes
Remote alarm notification	Email, network message (HTTP/HTTPS), SNMP, MxMessageSystem, MQTT
DVR/image storage management	<ul style="list-style-type: none"> <li>▪ On internal microSD card</li> <li>▪ On external USB and NAS devices</li> <li>▪ Different streams for live image and recording</li> <li>▪ MxPEG+ only</li> <li>▪ MxFFS with buffered archive, pre- and post-alarm images, storage monitoring with error reporting</li> </ul>
Camera and data security	User and group management, SSL connections, IP-based access control, IEEE 802.1X, intrusion detection, digital image signature
Digitally signed firmware	Yes (to prevent firmware file tampering)

## Video Analysis

Feature	Properties
Video motion detection	Yes
MxActivitySensor	Version 1.0, 2.1, 3.0 and object-based MxAnalytics AI
MxAnalytics	Yes
MOBOTIX App support	Yes

---

## Video Management Software

Feature	Properties
MOBOTIX HUB	Yes <a href="http://www.mobotix.com">www.mobotix.com</a> > <a href="#">Services</a> > <a href="#">Download Center</a> > <a href="#">Software Downloads</a>
MxManagementCenter	Yes (latest version recommended) <a href="http://www.mobotix.com">www.mobotix.com</a> > <a href="#">Services</a> > <a href="#">Download Center</a> > <a href="#">Software Downloads</a>
MOBOTIX Cloud	Streaming & Events supported
MOBOTIX LIVE App	Yes (available in Google Play Store (Android) and Apple App Store (iOS)).
3rd Party VMS Software	See ONVIF Profile S, T and G specification

# Sensor Modules

## Dimensions of Sensor Modules

Height x Width	58 x 42,5 (50 mm)	
Weight	Standard Sensor Modules	max. 150g
	Functional Modules	max. 150g
	Thermal Sensor Module B-Models	max. 380g
	Thermal Sensor Module C-Models	max. 220g
	PTMount Thermal	890g

## Supported Image Sensor Modules

Sensor Module	Order Code
Sensor module with standard 45° lens	Mx-O-M7SA-8DN100*
	Mx-O-M7SA-8D100
	Mx-O-M7SA-8N100*
	Mx-O-M7SA-4DN100
Sensor module with tele lens 30°	Mx-O-M7SA-8DN150*
	Mx-O-M7SA-8D150
	Mx-O-M7SA-8N150*
	Mx-O-M7SA-4DN150
	Mx-O-M7SA-8L150
Sensor module with tele lens 15°	Mx-O-M7SA-8DN280*
	Mx-O-M7SA-8D280
	Mx-O-M7SA-8N280*
	Mx-O-M7SA-4DN280
	Mx-O-M7SA-8L280
Sensor module with tele lens 8°	Mx-O-M7SA-8D500

## Technical Specifications

### Sensor Modules

---

Sensor Module	Order Code
	Mx-O-M7SA-8N500
	Mx-O-M7SA-8L500
Sensor module with wide angle lens 60°	Mx-O-M7SA-8DN080*
	Mx-O-M7SA-8D080
	Mx-O-M7SA-8N080*
	Mx-O-M7SA-4DN080
Sensor module with super wide angle lens 95°	Mx-O-M7SA-8DN050*
	Mx-O-M7SA-8D050
	Mx-O-M7SA-8N050*
	Mx-O-M7SA-4DN050
Sensor module with ultra wide angle lens 120° 4K	Mx-O-M7SA-8DN040*
	Mx-O-M7SA-8D040
	Mx-O-M7SA-8N040*
	Mx-O-M7SA-4DN040
	Mx-O-M7SA-8L040
Sensor module with hemispheric lens 180° 12MP	Mx-O-M7SA-12DN016*

\*also available in black.

---

#### NOTE!

Please consider any lens-related restrictions. For example, license plate recognition is not possible with a hemispheric lens.

For a complete list of lenses for MOBOTIX cameras, please see the Lens Table document for MOBOTIX 7 models on [www.mobotix.com > Services > Download Center > Marketing & Documentation > Lens Table](http://www.mobotix.com > Services > Download Center > Marketing & Documentation > Lens Table).

## Supported Thermal Sensor Modules

Sensor Module	Order Code
CIF Thermal 45° x 35°	MX-O-M7SB-336TS100
CIF Thermal 25° x 19°	Mx-O-M7SB-336TS150
CIF Thermal 17° x 13°	Mx-O-M7SB-336TS280
CIF Thermal Radiometry	Mx-O-M7SB-336RS100

---

Sensor Module	Order Code
45° x 35°	
CIF Thermal Radiometry 25° x 19°,	Mx-O-M7SB-336RS150
CIF Thermal Radiometry 17° x 13°	Mx-O-M7SB-336RS280
CIF Thermal Radiometry 9.3° x 7.1°	Mx-O-M7SB-336RS500 (BTO)
ECO CIF Thermal 105°x75°	Mx-O-M7SA-320T040
ECO CIF Thermal 56°x42°	Mx-O-M7SA-320T080
VGA Thermal 90° x 69°	Mx-O-M7SB-640TS050
VGA Thermal 69° x 56°	Mx-O-M7SB-640TS080
VGA Thermal 45° x 37°	Mx-O-M7SB-640TS100
VGA Thermal 32° x 26°	Mx-O-M7SB-640TS150
VGA Thermal Radiometry 90° x 69°	Mx-O-M7SB-640RS050
VGA Thermal Radiometry 69° x 56°	Mx-O-M7SB-640RS080
VGA Thermal Radiometry 45° x 37°	Mx-O-M7SB-640RS100
VGA Thermal Radiometry 32° x 26°	Mx-O-M7SB-640RS150
VGA Thermal Radiometry 18° x 14°	Mx-O-M7SB-640RS280 (BTO)

The **Thermal Radiometry (TR)** variants can automatically trigger alarms if the temperature exceeds or falls below defined limits. This is crucial for the detection of fire or heat sources. Up to 20 different temperature events can be configured simultaneously in TR windows or covering the full sensor image over a temperature range of High Sensitivity: -40 to 170 °C/-40 to 320 °F -- Low Sensivity: -40 to 550 °C/-40 to 1022 °F .

The **Thermal (non-TR)** variants only measure in the center of the image (Thermal spot, 2x2 pixel).

## Features Thermal Image Sensors – B-Models

Feature	Properties												
Thermal sensitivity	Typ. 50 mK												
Thermal image sensor	Uncooled microbolometer, CIF: 336 x 256 px / VGA: 640 x 480 px												
IR range	7.5 to 13.5 $\mu\text{m}$												
Temperature measurement range (adjustable)	High Sensitivity: -40 to 170°C/-40 to 320°F Low Sensivity: -40 to 550°C/-40 to 1022°F Default: Automatic (switches between High and Low depending on highest temperatures in FoV)												
Dimensions	336/640 px: 48.5x48 mm/48.5x70 mm; 170 g without front plate / 265 g with front plate												
Dimensions	PT mount Thermal 336/640 px: 98.5 mm x 106 mm diam; 620 g (including PT Mount) Sensor module alone: 73 mm (+4.4 mm front glass) x 57 mm diam (63 mm front glass); 310 g												
Max. image size	Can be scaled up to 3072 x 2048 (6MP), automatically scaled to size of MX sensor module												
Max. frame rate	9 fps (fast version 25/30 fps on request)												
Pixel pitch	17 $\mu\text{m}$												
Field of view	<table border="1"> <thead> <tr> <th>Sensor Module</th> <th>FoV</th> </tr> </thead> <tbody> <tr> <td>336R/T100</td> <td>45° x 35°; 2.27 mrad; focal length 7.5 mm, f/1.25</td> </tr> <tr> <td>336R/T150</td> <td>25° x 19°; 1.31 mrad; focal length 13 mm, f/1.25</td> </tr> <tr> <td>640R/T050</td> <td>90° x 69°; 2.27 mrad; focal length 7.5 mm, f/1.4</td> </tr> <tr> <td>640R/T100</td> <td>45° x 37°; 1.31 mrad; focal length 13 mm, f/1.25</td> </tr> <tr> <td>640R/T150</td> <td>32° x 26°; 0.90 mrad; focal length 19 mm, f/1.25</td> </tr> </tbody> </table>	Sensor Module	FoV	336R/T100	45° x 35°; 2.27 mrad; focal length 7.5 mm, f/1.25	336R/T150	25° x 19°; 1.31 mrad; focal length 13 mm, f/1.25	640R/T050	90° x 69°; 2.27 mrad; focal length 7.5 mm, f/1.4	640R/T100	45° x 37°; 1.31 mrad; focal length 13 mm, f/1.25	640R/T150	32° x 26°; 0.90 mrad; focal length 19 mm, f/1.25
Sensor Module	FoV												
336R/T100	45° x 35°; 2.27 mrad; focal length 7.5 mm, f/1.25												
336R/T150	25° x 19°; 1.31 mrad; focal length 13 mm, f/1.25												
640R/T050	90° x 69°; 2.27 mrad; focal length 7.5 mm, f/1.4												
640R/T100	45° x 37°; 1.31 mrad; focal length 13 mm, f/1.25												
640R/T150	32° x 26°; 0.90 mrad; focal length 19 mm, f/1.25												
Operating temperature range	-40 to 65 °C/-40 to 149 °F												
Relative Humidity	95 % non-condensing												
Power consumption	max. 1.2 W												

Feature	Properties
MTBF	80,000 hours
IP rating	IP67
IK rating	IK04
Material	PBT-30GF (housing); Germanium (lens)

## Features Thermal Image Sensors – C-Models

Feature	Properties												
Thermal sensitivity	Typ. 30 mK												
Thermal image sensor	Uncooled microbolometer, VGA: 640 x 480 px												
IR range	7.5 to 13.5µm												
Temperature measurement range (adjustable)	High Sensitivity: –40 to 150°C/–40 to 302°F Low Sensivity: –40 to 350°C/–40 to 662°F Default: Automatic (switches between High and Low depending on highest temperatures in FoV)												
Dimensions	PT mount Thermal 336/640 px: 98.5 x 106 mm diam., 620 g (including PT Mount) Sensor module alone: 73 mm (+4.4 mm front glass) x 57 mm diam. (63 mm front glass), 310 g												
Max. image size	Can be scaled up to 3072 x 2048 (6MP), automatically scaled to size of MX sensor module												
Max. frame rate	30 fps												
Pixel pitch	12 µm												
Field of view	<table border="1"> <thead> <tr> <th>Sensor Module</th> <th>FoV (H x V)</th> </tr> </thead> <tbody> <tr> <td>320R100</td> <td>50° x 40°; focal length 9.2 mm; f/1.0</td> </tr> <tr> <td>320T280</td> <td>12° x 9.6°; focal length 18 mm; f/1.0</td> </tr> <tr> <td>640R050</td> <td>95° x 76°; focal length 4.9 mm; f/1.1</td> </tr> <tr> <td>640R100</td> <td>50° x 40°; focal length 4.5 mm; f/1.2</td> </tr> <tr> <td>640T280</td> <td>18° x 14.4°; focal length 24.9 mm; f/1.0</td> </tr> </tbody> </table>	Sensor Module	FoV (H x V)	320R100	50° x 40°; focal length 9.2 mm; f/1.0	320T280	12° x 9.6°; focal length 18 mm; f/1.0	640R050	95° x 76°; focal length 4.9 mm; f/1.1	640R100	50° x 40°; focal length 4.5 mm; f/1.2	640T280	18° x 14.4°; focal length 24.9 mm; f/1.0
Sensor Module	FoV (H x V)												
320R100	50° x 40°; focal length 9.2 mm; f/1.0												
320T280	12° x 9.6°; focal length 18 mm; f/1.0												
640R050	95° x 76°; focal length 4.9 mm; f/1.1												
640R100	50° x 40°; focal length 4.5 mm; f/1.2												
640T280	18° x 14.4°; focal length 24.9 mm; f/1.0												

## Technical Specifications

### Sensor Modules

Feature	Properties
Operating temperature range	-40 to 65 °C/-40 to 149 °F
Relative Humidity	95 % non-condensing
Power consumption	1.5 W
MTBF	80,000 hours
IP rating	IP67
IK rating	IK04
Material	PBT-30GF (housing); Germanium (lens)

## Features ECO Thermal Image Sensor

Feature	Properties
Thermal sensitivity	Typ. 65 mK, IR range 7.8 to 14 μm
Temperature measurement range	-40 to 330°C/ -40 to 626 °F
Field of view	T040: 105 x 75°; 5.23mrad, focal length 2.2mm, f/1.05 T080: 56 x 42°; 3.00mrad, focal length 4.0mm, f/1.00
Thermal image sensor	Uncooled microbolometer, CIF: 320 x 240 pixels
Dimensions	58 x 42.5 mm (dia. 50 mm), 65g
Pixel pitch	12μm
Max. image size	Can be scaled up to 3072 x 2048 (6MP) (6MP), automatically scaled to size of MX Sensor module
Max. frame rate	9 fps (when displaying an Mx Sensor module and a thermal sensor module, the overall frame rate of the camera is reduced to 9 fps)
Operating temperature	-40° to +65°C / 40° to 149°F; 5% to 95% non-condensing
Power consumption	600mW
IP rating	IP66
IK rating	IK04

Feature	Properties
Material	PBT-30GF (housing); Chalcogenide (lens)
Software (included)	Video management software MxManagementCenter

## Functional Modules

Functional Module	Order Code	Remark
Audio module	Mx-F-S7A-INT01	Via S74 IO Slide in Board
MultiSense module	Mx-F-MSA	With PIR sensor, temperature sensor, illumination sensor
IR Light modules	Mx-F-IRA-W	For Super Wide-Angle Lens Sensor Modules 95°
	Mx-F-IRA-S	For Standard & Wide-Angle Lens Sensor Modules 45° and 60°
	Mx-F-IRA-T	For Tele Lens Sensor Modules 15° and 30°
		Power consumption IR Light Modules: 4.2 W at 100% brightness.
White Light Modules	Mx-F-WLA-W	For Super Wide-Angle Lens Sensor Modules 95°
	Mx-F-WLA-S	For Standard & Wide-Angle Lens Sensor Modules 45° and 60°
	Mx-F-WLA-T	For Tele Lens Sensor Modules 15° and 30°
		Power consumption White Light Modules: 3.2 W at 100% brightness.

## Interface Slide-in Boards

### S74 Network Slide-in Board with RJ45 socket

Order Code	Mx-F-S7A-RJ45
Power Supply	PoE Plus (802.3at-2009)/Class 4
Network	RJ45 / Ethernet 1000Base-T

### S74 Network Slide-in Board with LSA terminal

Order Code	Mx-F-S7A-LSA
Power Supply	PoE Plus (802.3at-2009)/Class 4
Network	LSA / Ethernet 1000Base-T
Overvoltage Protection	max. 4 kV on the PoE network cabling

### S74 IO Slide in Board

Order Code	Mx-F-S7A-INT01
------------	----------------

Terminal	Remark
Line Out	Headphones with 20mW @ 16 Ohm or 32 Ohm. Audio inputs as a Line Out function to 10k Ohm impedance of receiver. Audio level while connected to 10k Ohm equals -10dBV
Line In	Standard Line In: (0dB) Vrms=1V
SPK	0.9W at any 8 Ohm speaker. MOBOTIX Audio module: 0.9W at 8 Ohm
MIC	Passive microphone to connect (for best results). R_Bias for the microphone is 2.2 kOhm (included on the camera). Microphone impedance < 2.2 kOhm, Operating voltage of the microphone is 2V. Sensitivity of the MOBOTIX Audio Module: -35 +/-4dB (0dB = 1V/pa, 1kHz)

Terminal	Remark
Allowed cable dimensions for cables connected to the PCB terminals	<i>Conductor cross section</i>
	AWG 20 - 26
	Rigid 0.14mm <sup>2</sup> - 0.5mm <sup>2</sup>
	Flexible 0.14mm <sup>2</sup> - 0.5mm <sup>2</sup>
	Flexible with ferrule 0.25mm <sup>2</sup> - 0.34mm <sup>2</sup>
Input	<b>S74-A</b> requires pull-up resistor and external power supply (10mA / max 30 Vrms AC / max. 50V DC) Output may be loaded with max. 50mA max. length for cables: depends on loop impedance of the connected cable.
	<b>S74-B</b> Dry contact, form A (max 30 Vrms AC / max, 50V DC/ 60 W/ 2A DC)
Output	requires pull-up resistor and external power supply (10mA / max 30 Vrms AC / max. 50V DC) Output may be loaded with max. 50mA max. length for cables: depends on loop impedance of the connected cable.

## S74 Network Slide-in Board with RJ45 and VDC power supply - A

Order Code	Mx-F-S7A-RJ45-VDC
Power Supply	12-24 V DC only - recommended 2.5-1.5A
Network	RJ45 / Ethernet 1000Base-T

### Allowed cable dimensions for cables connected to the PCB terminals

AWG	26 - 20
Rigid	0.14mm <sup>2</sup> - 0.5mm <sup>2</sup>
Flexible	0.14mm <sup>2</sup> - 0.5mm <sup>2</sup>
Flexible with ferrule	0.25mm <sup>2</sup> - 0.34mm <sup>2</sup>

## S74 Network Slide-in Board with RJ45 and VDC power supply - B

Order Code	Mx-F-S7B-RJ45-VDC
Power Supply	12-24 V DC only - recommended 2.5-1.5A
Network	RJ45 / Ethernet 1000Base-T

### Allowed cable dimensions for cables connected to the PCB terminals

AWG	26 - 14
Rigid	0.14mm <sup>2</sup> - 2.5mm <sup>2</sup>
Flexible	0.14mm <sup>2</sup> - 1.5mm <sup>2</sup>
Flexible with ferrule	0.25mm <sup>2</sup> - 1.5mm <sup>2</sup>

## Dimensions

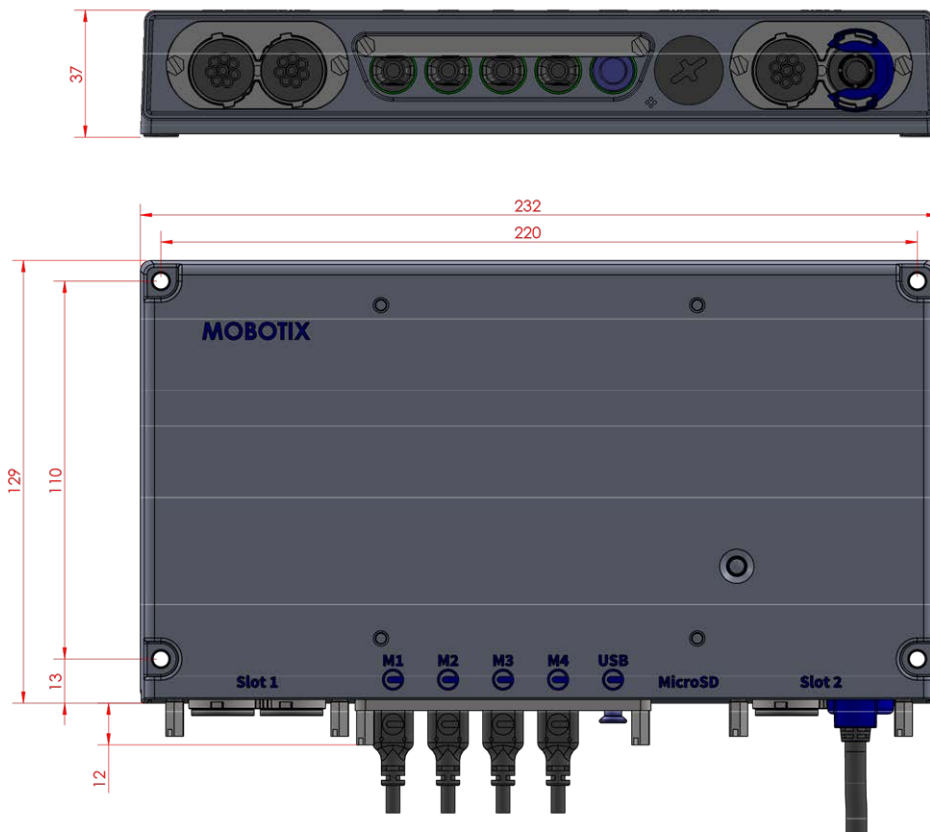

Fig. 1: MOBOTIX S74: All measurements in mm

**NOTE!** Drilling template: [www.mobotix.com](http://www.mobotix.com) > Support > Download Center > Marketing & Documentation > Drilling Templates.

## PTMount – Dimensions

**NOTE!** Drilling template: [www.mobotix.com](http://www.mobotix.com) > Support > Download Center > Marketing & Documentation > Drilling Templates.

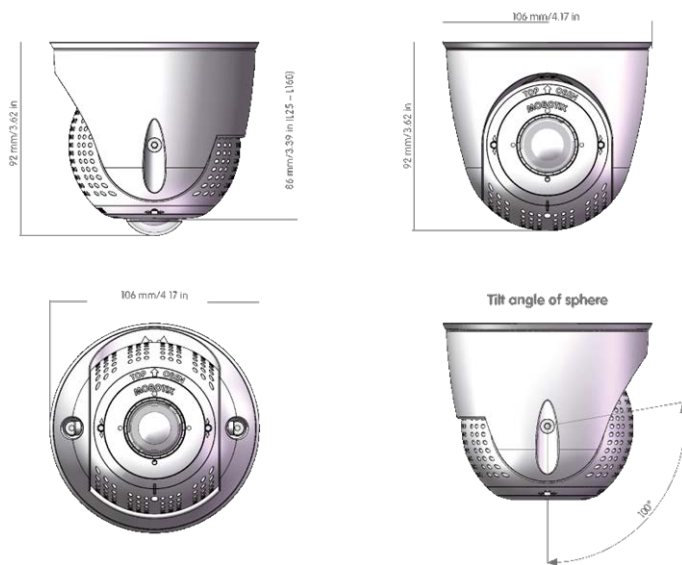

Fig. 2: PTMount

## PTMount-Thermal – Dimensions

**NOTE!** Drilling template: [www.mobotix.com](http://www.mobotix.com) > Support > Download Center > Marketing & Documentation > Drilling Templates.

# Technical Specifications

## Dimensions

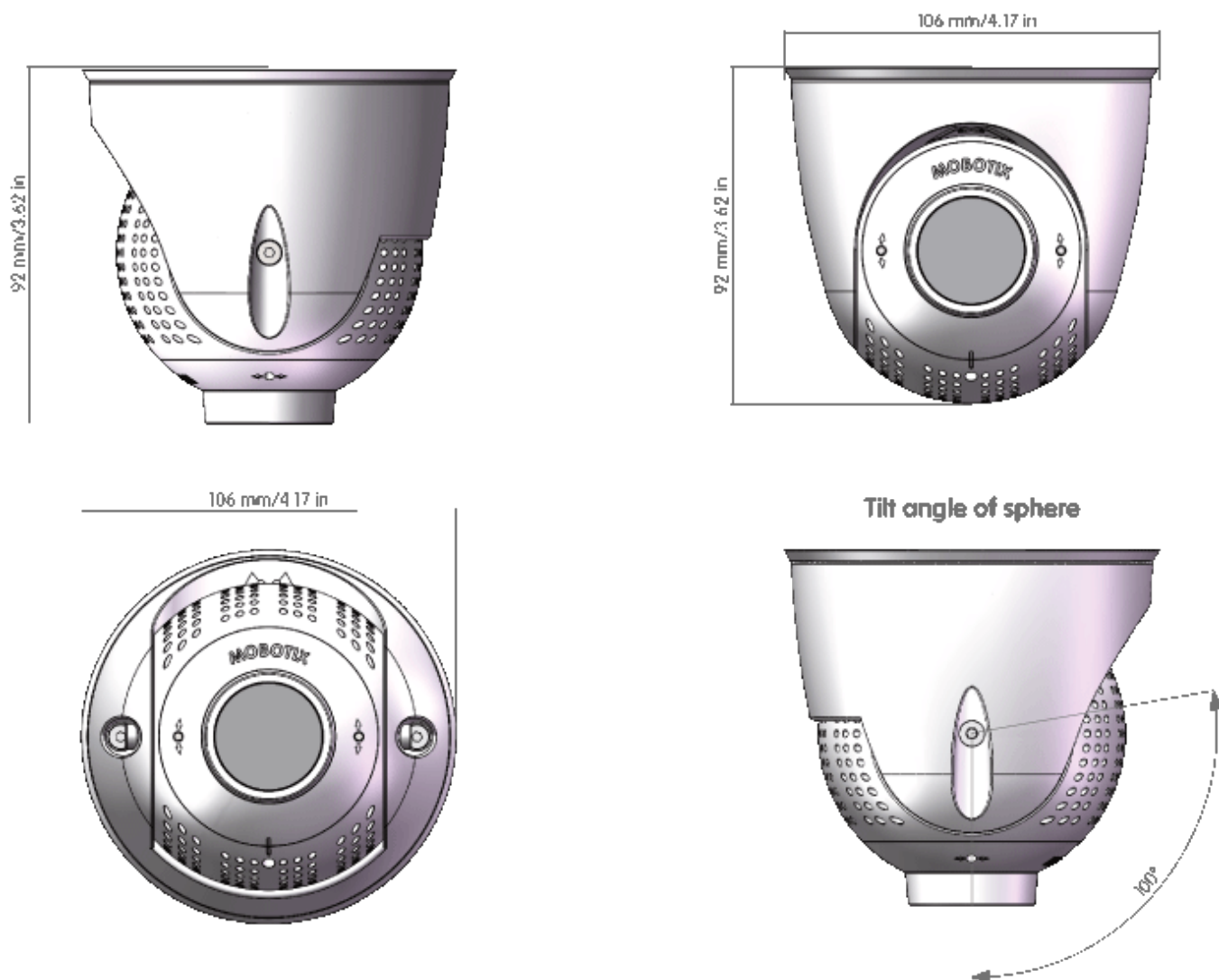

Fig. 3: PTMount-Thermal

## Mounting

This section contains the following information:

<b>Before Mounting the Camera</b> .....	<b>40</b>
<b>Installing Sensor Modules</b> .....	<b>42</b>
<b>Installing Slide-in Boards</b> .....	<b>51</b>
<b>Mounting the Camera</b> .....	<b>65</b>
<b>Connecting Module Cables to the Camera</b> .....	<b>66</b>
<b>Connecting the Camera to the Network</b> .....	<b>69</b>

# Before Mounting the Camera

Before mounting the MOBOTIX S74, the following questions should be answered:

- Where and how will the camera be mounted?
- Where and how will the sensor modules be mounted?
- How is the mounting surface level?
- Which other mounting options are available?
- Which accessories might be needed?
- How is the camera connected to the network and how is the power supplied?
- How are the connections furnished from the building?
- What cabling considerations are necessary?

#### CAUTION!

- Install only on a flat surface! Unevenness must not exceed 0.5 mm/0.02 in!
- Only use genuine MOBOTIX patch cables to guarantee the weatherproofness!

#### NOTE!

- Before mounting the camera, determine its ideal position and make sure that the field of view is not obstructed in any way. Once the camera has been mounted, you can fine-tune the image.
- If the monitored area changes or the camera has to be installed in a different location, you can simply exchange the sensor modules.

If you have questions, please ask your MOBOTIX partner directly or contact the MOBOTIX support under [www.mobotix.com](http://www.mobotix.com) > [Support](#) > [Help Desk](#).

## Protective Measures

#### WARNING!

When laying cables indoors and outdoors, the current regulations for cable laying, lightning and fire protection must always be observed.

MOBOTIX cameras and devices are protected against the effects of minor over voltages by a number of measures. However, these measures cannot prevent larger surge voltages from causing damage to the camera. When installing the cameras outdoors, special attention should therefore be paid to lightning protection and the associated dangers for the building and network infrastructure.

In general, you should only have MOBOTIX cameras and devices installed by certified specialist companies that are familiar with the installation and safe operation of network devices and the underlying regulations for lightning and fire protection as well as the current technology for preventing damage from surge voltages.

## Notes on Cable Laying

- **Data cable:** Only double-shielded CAT5 cable or better (S/STP) may be used as data cable for the Ethernet interface.

### NOTE!

For outdoor use, special requirements apply for the cables to be used and the lightning protection.

- **Cable length:** The individual cable sections must not exceed the maximum permissible lengths in order to ensure perfect data transmission.
- **Avoidance of induction:** Data cables may only be laid parallel to power or high-voltage lines if the prescribed minimum distances are observed.

## Fire Protection

When laying cables for the power supply, the relevant country-specific regulations (e.g. VDE in Germany) and the fire protection regulations valid at the installation site must be observed.

## Lightning and Surge Protection

Measures should always be taken to protect this device from electrical surge damage.

### NOTE!

Electrical surge protection is integrated in the S74 Network Slide-in Board with LSA terminal (see [Installing the S74 Network Slide-in Board with LSA terminal, p. 52](#)), which is available as an accessory.

Further information on how to avoid damage caused by lightning and over voltage is available from manufacturers of lightning and over voltage protection devices.

# Installing Sensor Modules

**WARNING!**

- Always power down the camera before installing or replacing sensor modules.  
Unplugging or connecting sensor modules of a powered-on camera can irreparably damage the sensor modules and the camera!
- When installing the sensor modules, make sure that the sensor module cables are not damaged or bent sharply.

**CAUTION!**

When installing the sensor modules, make sure that the sensor module cables are not damaged or bent sharply!

## Preparing the Sensor Modules

Remove the plastic nut ① from the sensor modules, remove the bayonet catch ② by rotating it counter-clockwise, then remove the blue rubber plug ③ .

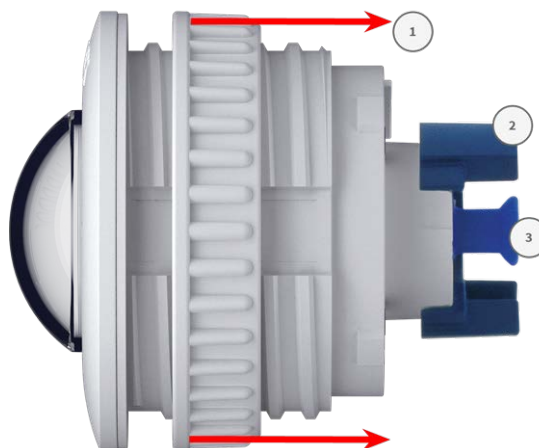

### Proceed by Installing the Sensor Modules

- [Installing Sensor Module without Mounts, p. 43](#)
- [Installing Sensor Module with PTMount, p. 44](#)
- [Installing Sensor Module PTMount-Thermal, p. 48](#)

## Installing Sensor Module without Mounts

1. **Mount the sensor module:** Insert sensor module into hole (43 mm) ① and tighten the plastic nut ② to keep the sensor module safely in place

2. **Connect the sensor module cable:** Push the plug of each sensor module cable **firmly** into the connector at the back of the module until the connector is fully inserted into its seat.

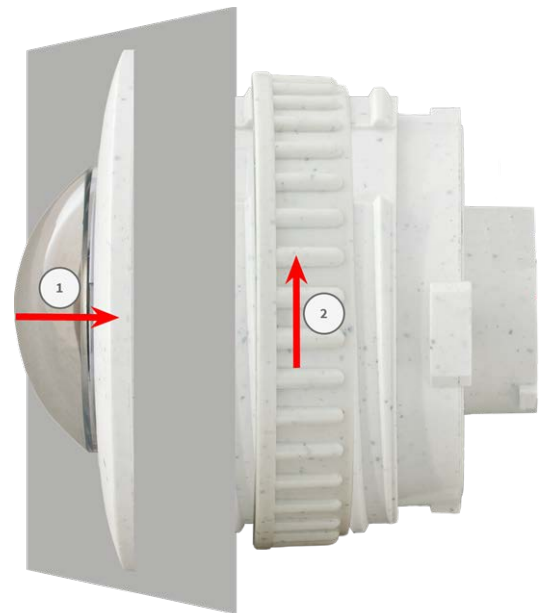

### CAUTION!

The lug of the plug must point to the inside of the sensor module when plugged in. If the module cable is not plugged in correctly, the sensor will not be recognized by the camera.

3. **Lock sensor module cable:** Apply the blue bayonet catch onto the connector of the sensor module as shown and turn it clockwise until it gently snaps shut.
4. Repeat steps 1 to 4 to add additional sensor modules, respectively.



## Installing Sensor Module with PTMount

### CAUTION!

The PT-Mount was developed for wall or ceiling mounting. When mounting on the floor, make sure that there is no cavity inside the PT-Mount where water could collect.

1. Using the 2.5 mm allen wrench, remove the two screws that hold the foot onto the swivel ring.
2. Remove swivel ring and base plate.



a-

Make sure that there is enough space for installing the PTMount and that you can access it from the rear later on. The surface should be even and smooth so that the sealing lies flat on the surface.

4. Drill the holes for the base plate using the drilling template and insert the screw anchors [PTMount: Scope of Delivery, p. 18](#).



5. In the center of the drilling template, drill another hole into the wall or faceplate for the sensor module cable. The hole should have a diameter between 15 and 35 mm.



6. Hold the sealing, the swivel ring and the base plate as shown in the figure.

7. Attach the base plate using the supplied wood screws and washers.

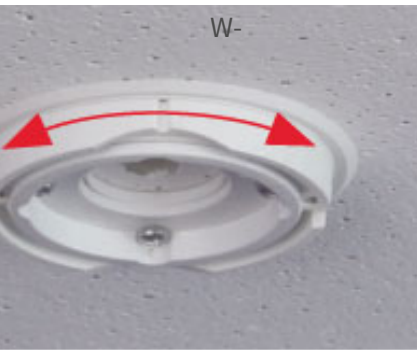
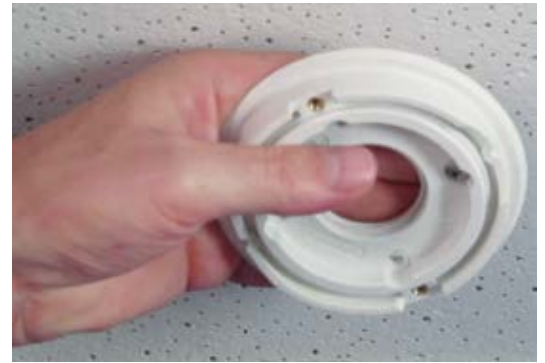

h-

When tightening the screws, make sure that you can still rotate the swivel ring by hand.

9. Guide the sensor cable through the sealing, the swivel ring, the base plate and through the mounting surface to the camera.

10. Guide the sensor cable from the back into the foot and the sphere.

11. Use the two screws to affix the foot and sphere assembly to the swivel ring and make sure that the foot can still be rotated.



## Mounting

### Installing Sensor Modules

---

12. Loosen the two fastening screws of the insert ① , then rotate the insert so that the small bar opposite of the **TOP/OBEN** label points to the hole of the grub screw ② .

13. Secure the insert against rotating by tightening the two fastening screws using the 2.5 mm Allen wrench.

14. Attach the sensor module cable to the sensor module (turn blue bayonet catch to the left and remove, pull out the plug, connect the sensor cable, apply bayonet catch and lock by turning to the right).

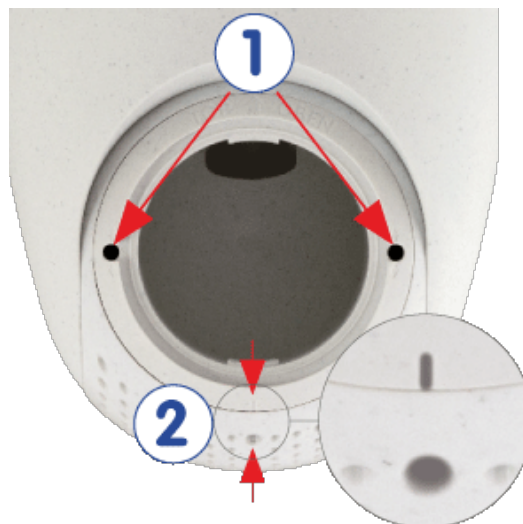

15. Push the sensor module into the PTMount so that the arrow on the backside of the sensor module points to the left vs. the **TOP/OBEN** lettering.



- Using the module wrench lock the sensor module by turning it 90 degrees to the right.



- Secure the sensor module by tightening the grub screw using the 2.5 mm Allen wrench. The grub screw locks the sensor module within the insert and prevents inadvertent unlocking of the sensor module.

- Adjust the sensor module temporarily by pointing it into the desired viewing direction.



## Mounting

### Installing Sensor Modules

---

19. Make sure that the **TOP/OBEN** label on the insert is pointing upwards. If this is not the case, loosen the two fastening screws using the 2.5 mm Allen wrench and rotate the insert.



## Installing Sensor Module PTMount-Thermal

1. Using the 2.5 mm Allen wrench, remove the two screws that hold the foot onto the swivel ring.
2. Remove swivel ring and base plate.
3. Make sure that there is enough space for installing the PTMount-Thermal and that you can access it from the rear later on. The surface should be even and smooth so that the sealing lies flat on the surface.



4. Use the base plate as drilling template, drill the holes for the base plate and insert the screw anchors [PTMount-Thermal: Scope of Delivery](#), p. 20.



5. In the center of the drilling template, drill another hole into the wall or faceplate for the sensor module cable. The hole should have a diameter between 15 and 35 mm.



6. Attach the base plate and the swivel ring using the supplied wood screws and washers.  
When tightening the screws, make sure that you can still rotate the swivel ring by hand.



## Mounting

### Installing Sensor Modules

7. Guide the sensor cable through the swivel ring and the base plate.
8. Use the two screws to affix the foot and sphere assembly to the swivel ring and make sure that the foot can still be rotated.
9. A-



- j-  
Adjust the sensor module temporarily by pointing it into the desired viewing direction.

10. Make sure that the **MOBOTIX** label on the insert is pointing upwards. If this is not the case, loosen the two fastening screws with the 2 mm Allen wrench and rotate the insert. Lightly tighten the two fastening screws.



## Installing Slide-in Boards

### WARNING!

Make sure the power supply to the camera is disconnected before installing or replacing slide in board.

## Installing the S74 Network Slide-in Board with RJ45 socket

The S74 Network Slide-in Board with RJ45 socket is required to connect the camera to the network and to supply power via PoE. The S74 Network Slide-in Board with RJ45 socket is not part of the scope of delivery (see [Delivered Parts and Dimensions](#)) and must be ordered separately.



### CAUTION!

The S74 Network Slide-in Board with RJ45 socket may only be installed in slot 2 of the camera!

#### CAUTION!

#### Do not connect to the network at this stage!

Since the camera must not run without sensor modules, the network connection will be established only **after** mounting the camera and connecting the sensor modules.

## Procedure

1. **Remove cover from slot 2 of the camera:** Use a screwdriver to loosen both bolt screws ① and then pull out the plastic cover.

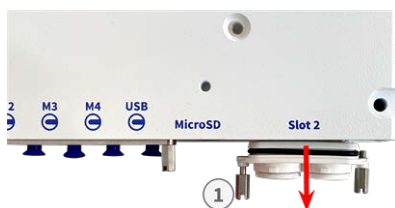

2. **Connect the S74 Network Slide-in Board with RJ45 socket:** Position the interface board on the guide rails in the slide-in slot and push it in with slight pressure until it clicks into the socket. Then fix the board with the screw bolts ①.

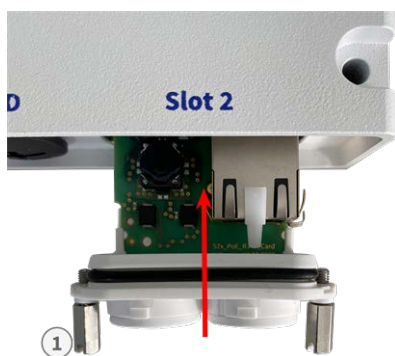

#### CAUTION!

**Do not connect the network cable at this stage!** Since the camera must not run without sensor modules, the network connection will be established only **after** mounting the camera and connecting the sensor modules.

## Installing the S74 Network Slide-in Board with LSA terminal

The S74 Network Slide-in Board with LSA terminal is required to connect the camera to the network, to supply power via PoE and to protect the camera from electrical surge. The S74 Network Slide-in Board with LSA

terminal is not part of the scope of delivery (see [Delivered Parts and Dimensions](#)) and must be ordered separately.



**CAUTION!**

The S74 Network Slide-in Board with LSA terminal may only be installed in slot 2 of the camera!

**CAUTION!**

**Do not connect to the network at this stage!**

Since the camera must not run without sensor modules, the network connection will be established only **after** mounting the camera and connecting the sensor modules.

## Prepare S74 Network Slide-in Board with LSA terminal and cable

**NOTE!**

You will need an LSA+/Krone tool for this procedure:



Fig. 4: LSA+/Krone tool

1. **Remove cover from slot 2 of the camera:** Use a screwdriver to loosen both bolt screws ① and then pull out the plastic cover.



## Mounting

### Installing Slide-in Boards

---

2. Cut off two steps of the of the white plug in the cover of the interface board ① .

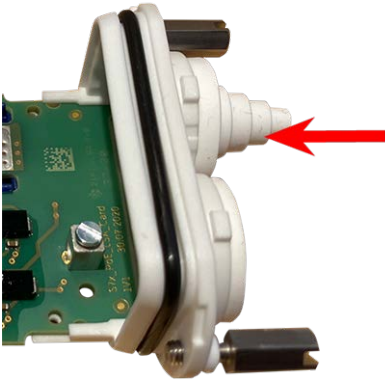

3. Insert the network cable into the white rubber plug:



4. Remove the insulation from the network cable as shown below:

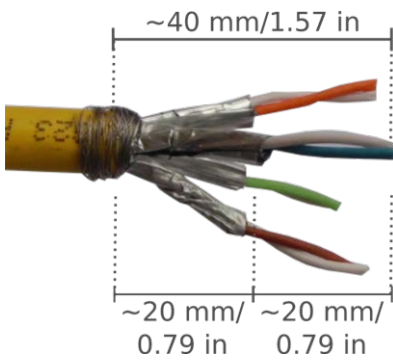

## Attach the Network Cable to the S74 Network Slide-in Board with LSA terminal

1. Insert the network cable into the interface board and make sure the rubber plug is properly seated all around the opening:

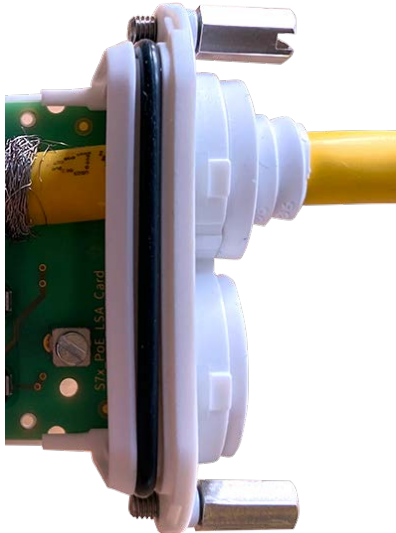

2. Insert the cable tie into the blue guides ①, tie down the network cable ② onto the copper-colored ground plate and cut off the protruding part of the cable tie:

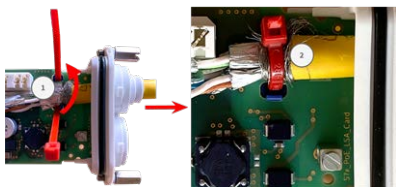

Fig. 5: Cable tie inserted beneath network cable

3. Prepare the LSA+/Krone tool:

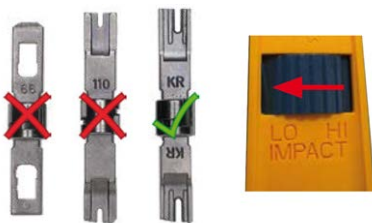

Fig. 6: LSA+/Krone tool set to LOW impact

### CAUTION!

Always use the proper LSA+/Krone blade and **set the tool to LOW impact.**

## Mounting

### Installing Slide-in Boards

---

4. Connect the wires of the network cable using the LSA+/Krone tool according to the color code sticker inside the box:



#### **CAUTION!**

Remove all clipped wire ends to prevent short circuits.

## Attach the Ground Wire to the S74 Network Slide-in Board with LSA terminal

#### **WARNING!**

For surge protection it is strongly recommended to attach the ground wire!

The maximum length of the ground wire should be 1 m/3.28 ft to the ground potential (e.g. a potential equalization rail, a grounded pole or a grounding rod).

1. Insert the ground wire into the white single-wire rubber plug:

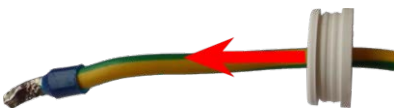

2. Insert the ground wire into the opening of the board and make sure the rubber plug is properly seated all around the opening:

- Loosen the screw of the ground wire terminal ① , insert the ground wire and properly fasten the screw of the terminal:

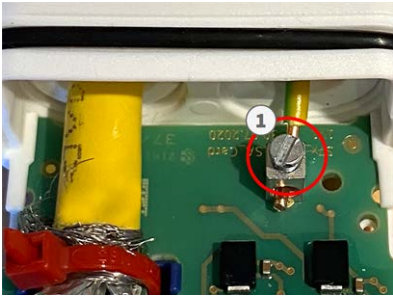

## Connect the S74 Network Slide-in Board with LSA terminal with the camera

- Position the interface board on the guide rails in the slide-in slot and push it in with slight pressure until it clicks into the socket. Then fix the board with the screw bolts ① .

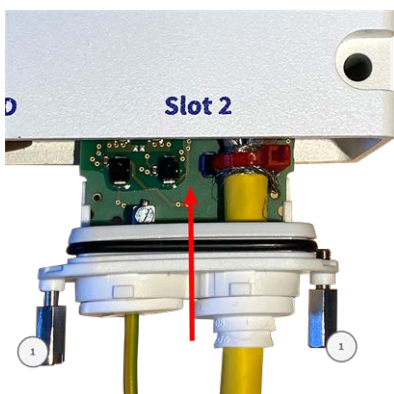

### CAUTION!

**Do not connect to the network at this stage!**

Since the camera must not run without sensor modules, the network connection will be established only **after** mounting the camera and connecting the sensor modules.

## Installing the S74 Network Slide-in Board with RJ45 and VDC power supply

The S74 Network Slide-in Board with RJ45 and VDC power supply is designed for powering the camera from an external power source and connecting it to the network. The board is not part of the scope of delivery (see [Delivered Parts and Dimensions](#)) and must be ordered separately.

## Mounting

### Installing Slide-in Boards



#### CAUTION!

The S74 Network Slide-in Board with RJ45 and VDC power supply may only be installed in slot 2 of the camera!

#### CAUTION!

**Do not connect to the network at this stage!**

Since the camera must not run without sensor modules, the network connection will be established only **after** mounting the camera and connecting the sensor modules.

## Procedure

1. **Remove cover from slot 2 of the camera:** Use a screwdriver to loosen both bolt screws ① and then pull out the plastic cover.

2. Insert the power cable into the white single-wire rubber plug.



3. Insert the power cable into the opening of the board and make sure the rubber plug is properly seated all around the opening.



4. Loosen the screws of the power terminal ① , insert the wires of the cable and properly fasten the screws of the terminal.



**CAUTION!**

Ensure the correct polarity!

5. Position the interface board on the guide rails in the slide-in slot and push it in with slight pressure until it clicks into the socket. Then fix the board with the screw bolts ① .

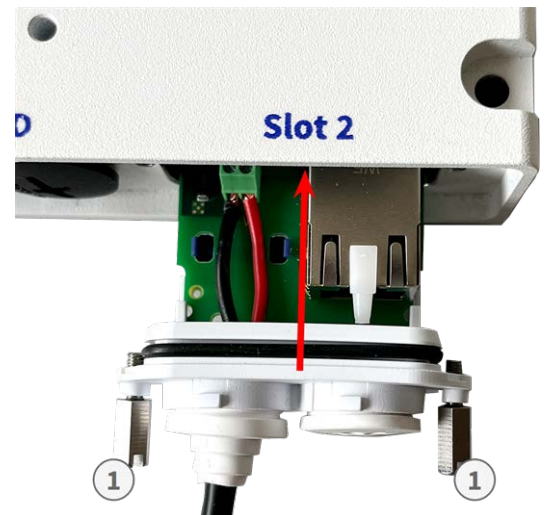

**CAUTION!**

**Do not connect to the network at this stage!**

Since the camera must not run without sensor modules, the network connection will be established only **after** mounting the camera and connecting the sensor modules.

## Installing the S74 IO Slide in Board

The S74 IO Slide in Board is designed for powering the camera from an external power source and connecting it to the network. The board is not part of the scope of delivery (see [Delivered Parts and Dimensions](#)) and must be ordered separately.

## Mounting

### Installing Slide-in Boards

---

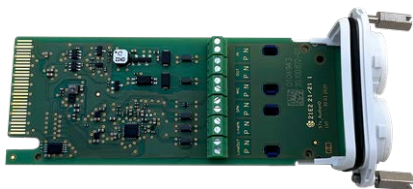

#### CAUTION!

The S74 IO Slide in Board may only be installed in slot 1 of the camera!

#### CAUTION!

##### Do not connect to the network at this stage!

Since the camera must not run without sensor modules, the network connection will be established only **after** mounting the camera and connecting the sensor modules.

#### CAUTION!

Observe the technical specifications of the connector boxes (see [S74 IO Slide in Board, p. 34](#)).

## Procedure

1. **Remove cover from slot 1 of the camera:** Use a screwdriver to loosen both bolt screws ① and then pull out the plastic cover.



Insert the I/O device cables into the white single-wire rubber plug:



2. Insert the I/O device cables into the opening of the board and make sure the rubber plug is properly seated all around the opening.

- Loosen the screws of the related I/O device terminal ① , insert the wires of the cable and properly fasten the screws of the terminal:

**CAUTION!**

Ensure the correct polarity!

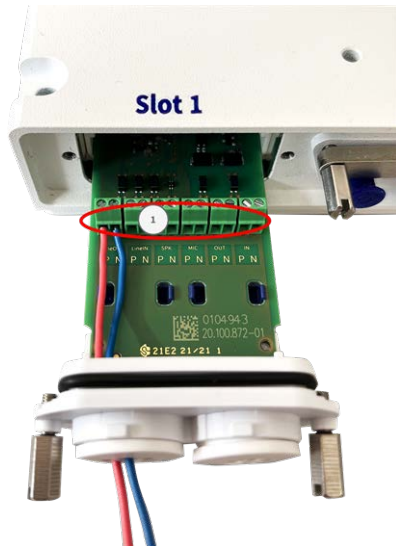

- Position the interface board on the guide rails in the slide-in slot and push it in with slight pressure until it clicks into the socket. Then fix the board with the screw bolts ① .

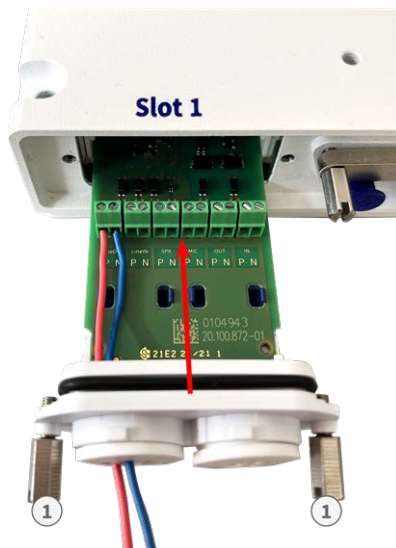

**CAUTION!**

**Do not connect to the network at this stage!**

Since the camera must not run without sensor modules, the network connection will be established only **after** mounting the camera and connecting the sensor modules.

## Terminal Connectors

All I/O connections to the camera can be made on the S74 IO Slide in Board which is not part of the part of scope of delivery of the camera.

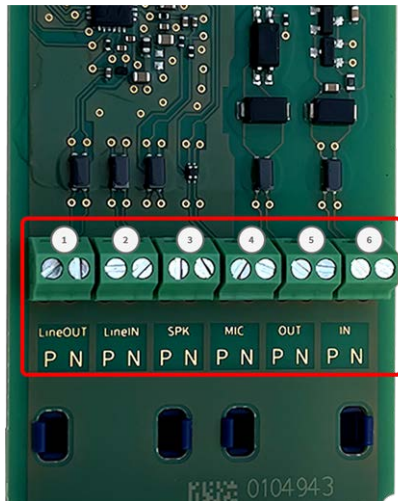

### Allowed cable dimensions for cables connected to the PCB terminals

AWG	20 - 26
Rigid	0.14mm <sup>2</sup> - 0.5mm <sup>2</sup>
Flexible	0.14mm <sup>2</sup> - 0.5mm <sup>2</sup>
Flexible with ferrule	0.25mm <sup>2</sup> - 0.34mm <sup>2</sup>

Terminal	Remark
Line Out	Headphones with 20mW @ 16 Ohm or 32 Ohm. Audio inputs as a Line Out function to 10k Ohm impedance of receiver. Audio level while connected to 10k Ohm equals -10dbV
Line In	Standard Line In: (0dB) Vrms=1V
SPK	0.9W at any 8 Ohm speaker.
MIC	Passive microphone to connect (for best results). R_Bias for the microphone is 2.2 kOhm (included on the camera). Microphone impedance < 2.2 kOhm, Operating voltage of the microphone is 2V.

Terminal	Remark
IN	<ul style="list-style-type: none"> <li>▪ Contact Closure (no galvanic isolation necessary) or up to 50V AC/DC</li> <li>▪ max. length for cables: 50m</li> </ul>
OUT	<ul style="list-style-type: none"> <li>▪ requires pull-up resistor and external power supply (10mA / max. 50V DC - no AC)</li> <li>▪ Output may be loaded with max. 50mA</li> <li>▪ max. length for cables: depends on loop impedance of the connected cable.</li> </ul>

### Example: switching an LED light using the P7 outputs

The outputs in the S74 interface board are using an optocoupler with an open collector.

- The outputs will require the use of an external DC power supply up to 50 volts.
- The optimal output current of the optocoupler output is around 10mA.
- The maximum limit of the output current is 50mA.
- This must be maintained by an external pull-up resistor.

#### NOTE!

They outputs are not capable of dry connect closure or direct use with AC power

The example shows a simple low voltage low current application such as switching an LED light using the P7 outputs.

The value of the pullup resistor depends on the forward voltage of the LED at the specific current you want to run through it.

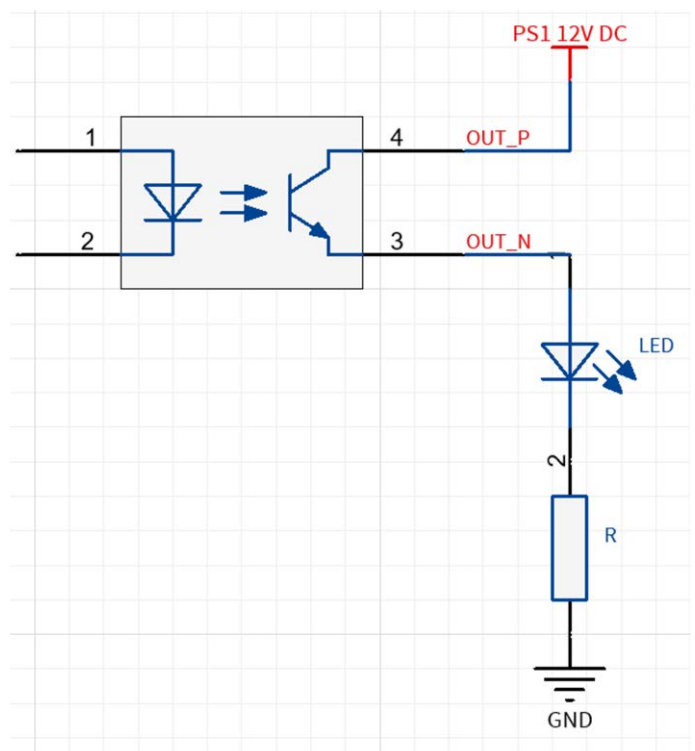

## Mounting

### Installing Slide-in Boards

#### EXAMPLE:

- Amperage through LED: 10mA
- LED Forward Voltage @ 10mA: 2 V
- Power supply: 12V DC
- Resistor value =  $(12V - 2V) / 10mA = 1 \text{ k}\Omega$

#### NOTE!

For further examples take a look at the MOBOTIX Online Community: <https://community.mobotix.com/>

## Connecting the Audio Cable Mx-A-S7A-AUCBL05-AN

The cable is designed for connecting the MOBOTIX 7 Audio Module to the Audio IO of the S74 IO Slide in Board. The cable is not part of the scope of delivery (see [Delivered Parts and Dimensions](#)) and must be ordered separately.



Fig. 7: Audio cable with two wire pairs

Connect the cable to the S74 IO Slide in Board (see [Installing the S74 IO Slide in Board, p. 59](#)) according to the following table:

Wire color	Terminal (Signal)
Blue	MIC P
Red / White	MIC N
Yellow	SPK P
White	SPK N

# Mounting the Camera

You can mount the S74 to any even surface.

Before mounting the MOBOTIX S74 and sensor modules, determine the ideal positions and make sure that the field of view is not obstructed in any way. Once the modules have been mounted, you can fine-tune the image. If the monitored area changes or the camera has to be installed in a different location, you can exchange the sensor modules.

Before mounting the camera, make sure that a network connection with power supply according to the PoE Plus (802.3at-2009) standard is available at the mounting position (see [Connecting the Camera to the Network](#), p. 69).

**NOTE!** Drilling template: [www.mobotix.com](http://www.mobotix.com) > Support > Download Center > Marketing & Documentation > Drilling Templates.

**NOTE!**

Do not use the dowels if the installation surface is wood. Only use the screws to fasten the mounting plate directly on the surface. In order to facilitate screwing in wood, the positions should first be pre-drilled using a 2 mm drill bit, for example (drilling depth just slightly less than screw length).

## Step by Step

1. **Drill the holes:** Mark the holes for drilling using the drilling template (see [Drilling Template](#)). When drilling, use an 8 mm drill bit and drill holes with at least 60 mm/1.2 in depth.
2. Fully push the dowels [M.5, p. 17](#) into the holes you drilled.
3. **Install the mounting plate:** Place the Camera over the drilled holes (1) and use the four screws [M.4, p. 17](#) with one washer [M.6, p. 17](#) each and the Phillips screwdriver to mount the plate to the wall.



**CAUTION!**

Install on flat surface only.

# Connecting Module Cables to the Camera

**WARNING!**

- Always power down the camera before installing or replacing sensor modules.  
Unplugging or connecting sensor modules of a powered-on camera can irreparably damage the sensor modules and the camera!
- When installing the sensor modules, make sure that the sensor module cables are not damaged or bent sharply.

Up to 4 sensor modules can be connected to the camera. Additionally a USB-C interface is available.



Fig. 8: 4 Module Connector Ports and 1 USB-C interface

## Step by Step

1. Use a screwdriver to loosen both bolt screws ① and then pull of the module latch.

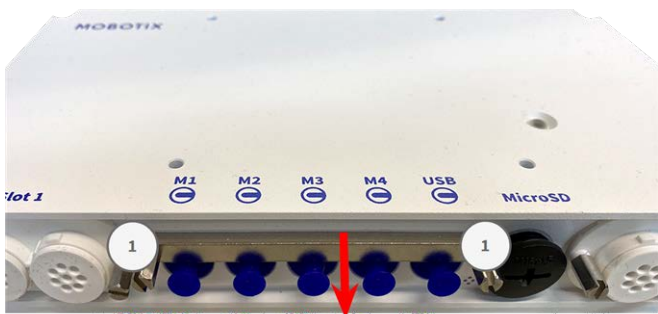

- Remove the blue rubber plug ① from the module connector.



- Plug the module cable into the module connector ① so that the small lug ② plug fits into the module connector.



**CAUTION!**

If the module cable is not plugged in correctly, the sensor is not recognized by the camera.

- Fasten the module latch by fastening the two bolt screws shown below.

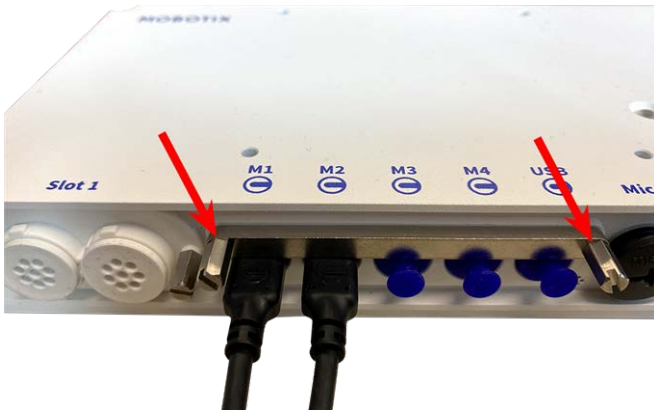

- Repeat steps 1 to 5 to connect additional modules.

## Sensor Module Combinations

**CAUTION!**

- A maximum of two optical modules can be used.
- One thermal module can be used instead of one **optical** module.
- A maximum of two functional modules can be used.

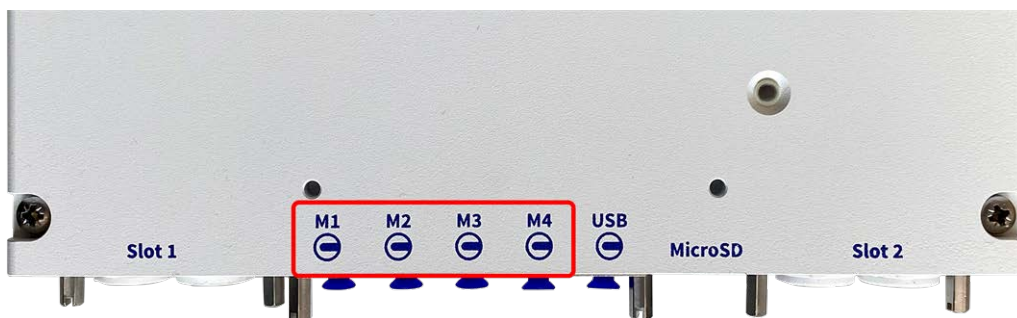

You can use the following combinations of sensor modules, thermal, and functional modules on the MOBOTIX S74:

Module	Module Connectors				Comments
	M1	M2	M3	M4	
<b>Optical Sensor Modules</b>					
all optical modules	yes	yes	no	no	
<b>Thermal Sensor Modules</b>					
all <b>A</b> -Variants	no	no	yes	no	e.g. Mx-O-M7SA-640R050
all <b>B</b> -Variants	yes	yes	yes	no	e.g. Mx-O-M7SB-640R050
<b>IR &amp; White Light Modules</b>					
all IR & white light modules	yes	yes	yes	yes	
<b>Other Functional Modules</b>					



## Connecting the S74 Network Slide-in Board with RJ45 socket

1. Remove the white rubber plug from the RJ45 network connector.
2. Plug the network cable of the camera into the network connector firmly until the blue sealing ring clicks into place.



- 3.

## Connecting the S74 Network Slide-in Board with LSA terminal

1. Plug the network cable of the camera into a PoE network connector of the network switch.

## Operating the Camera

This section contains the following information:

<b>Getting Started</b> .....	<b>71</b>
<b>Boot Options of the Camera</b> .....	<b>73</b>
<b>Initial Camera Setup</b> .....	<b>75</b>
<b>Focusing the TELE 15° Sensor Module</b> .....	<b>81</b>

### Getting Started

You can use the MOBOTIX S74 with any current browser – or with MxManagementCenter.

You can download MxManagementCenter free-of-charge from [www.mobotix.com](http://www.mobotix.com) > [Services > Download Center > Software Downloads](#).

1. **Connect the camera to the network.** The network cable will also provide power to the camera(see [Connecting the Camera to the Network](#), p. 69).
  1. **Establish a connection to the camera and adjust the network settings if required:** By factory default, MOBOTIX cameras are booting as DHCP client with an additional fixed IP address in the 10.x.x.x range (e.g., 10.16.0.128). Local computer networks usually have IP addresses in the 172 or 192 ranges. Depending on whether a DHCP server is present on the local network or if the network has been set up to use fixed IP addresses, there are several possibilities for establishing a connection to the camera and to change its [Network Settings](#):
    - **Network with dynamic IP addresses**

**Using a browser:** If you know the IP address that the DHCP server assigned to the camera, simply enter that address in the browser address bar to directly connect to the camera

**Using MxManagementCenter:** With MxManagementCenter, you can show and integrate the camera without having to know its current IP address.
    - **Network with static IP addresses**

In order to access the camera, it must have an IP address within the range of the local network. To set the camera's network parameters, you can use one of these methods:

**Manually using a web browser:** You may have to adjust the network settings of your computer.
    - **Automatically using MxManagementCenter:** The camera is displayed in MxManagementCenter although the IP address is not part of the local network, allowing you to reconfigure its settings.
2. **Configure camera:** You can use the user interface of the camera in a browser or in MxManagementCenter.

## LED states

Camera LED on top of the camera body displays the following states by default:

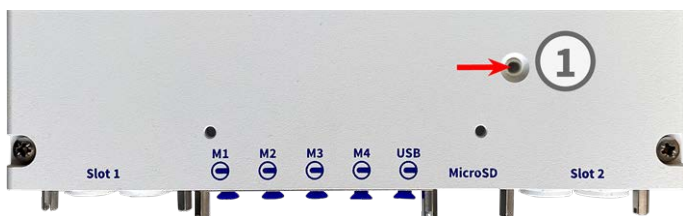

### LED status

### Meaning

green steady on	normal operation
green steady flashing	technical error or misconfiguration

---

# Boot Options of the Camera

By default, the camera starts as DHCP client and automatically tries to get an IP address from a DHCP server. To start the camera in a mode different from the default mode, you can activate the boot menu of the camera.

## NOTE!

Pressing the key of the camera will let the camera announce the current IP address of the camera on the speaker (if a speaker is attached to the camera).

## CAUTION!

When opening the camera, do not insert any objects into the housing. This could damage the camera!

1. Disconnect the camera's power supply.
2. Remove the black cover screw ① with a screwdriver.
3. Take a suitable tool for operating the boot menu (e.g. the enclosed tweezers [M.3, p. 17](#)), **but do not use a paper clip or pointed objects!**
4. Reconnect the power supply of the camera.
5. **Activate the boot menu:** The LED at the top of the camera housing lights up 5 to 10 seconds after establishing the power supply and will stay on for 10 seconds. Press the reset key ② with the tool. The camera enters the boot menu, ready for selecting one of the boot options. The LED will flash once. The flash signal will be repeated every second.



## NOTE!

The number of flashes corresponds to the current boot option.

6. **Switch the boot option:** Briefly press the reset button (< 1 sec). After the last boot option, the camera returns to the first boot option (LED flashes once).

7. **Select a boot option:** Press the key longer (> 2 sec). The camera confirms the selection by flashing the LED rapidly for 3 seconds. After 20 sec, the camera will play a sound according to the table below.

LED Flashes	Boot Option	Meaning	Audio Confirmation
1x	•/•	This option is not supported on this camera model.	•/•
2x	Factory Defaults	Starts the camera with factory defaults (factory default IP address, users and passwords will not be reset).	<b>Boing</b>
3x	Automatic IP Address	Starts the camera as DHCP client and tries to obtain an IP address from a DHCP server. If a DHCP server cannot be found or no IP address can be obtained, the camera starts with its factory default address.	<b>Boing-Boing</b>
4x	Backup Operating System	Starts the camera with the recovery system, e.g., in order to recover from a failed update of the camera software.	<b>Alarm Sound</b>

---

8. Close the SD card housing.

#### NOTE!

##### Starting the Camera With Factory Defaults or an Automatic IP Address (DHCP)

The configurations loaded when using the boot options 2 and 3 will not be automatically saved to the camera's flash memory. Upon starting the camera the next time, the camera will use the last configuration it stored. You can store the configuration in the camera's flash memory using the **Admin Menu > Store** command.

**CAUTION!**

- Note that you can restore specific parts of the camera configuration afterward by using "Restore" to re-apply the settings still stored in the camera.
- As opposed to resetting the camera using **Admin Menu > Reset configuration to factory defaults**, the user information will not be reset if the camera is booted using the factory defaults.
- When starting the camera with DHCP support (option 2), make sure that the network has a properly functioning DHCP server. If this is not the case, the camera cannot obtain a valid IP address and will fall back to its last IP address.
- You should also make sure that the cameras always get the same IP addresses by mapping the MAC addresses of the cameras to the desired IP addresses.

## Initial Camera Setup

### Check the Preconditions

- Is the camera running (check camera power LED)?
- Is the camera accessible using my current network connection?
- Do I have the necessary information for successfully running the camera on the network?
  - IP address of NTP (*Network Time Protocol*) server.
  - IP address of network gateway (if required).

## Access the Camera

1. Start your web browser.
2. Access the camera using its zeroconf address:
  - Look for the factory IP address such as 10 . x . y . z on the sticker on the camera body or the packaging.
  - Enter this address in the address bar of your browser using the following syntax: mx10-x-y-z.local.

**EXAMPLE:** Taking a factory IP address of 10 . 32 . 24 . 129 as an example, you would enter mx10-32-24-129.local in the address bar of your browser.

- Click on **Admin Menu** and enter the default access credentials (admin/meinsm).
3. In the **Quick Installation** dialog, select your language, then click on .



4. Continue clicking on  and do not change any settings until you reach the **Security** dialog. Set a password for the admin user of the camera. Make sure you keep the password in a safe place.

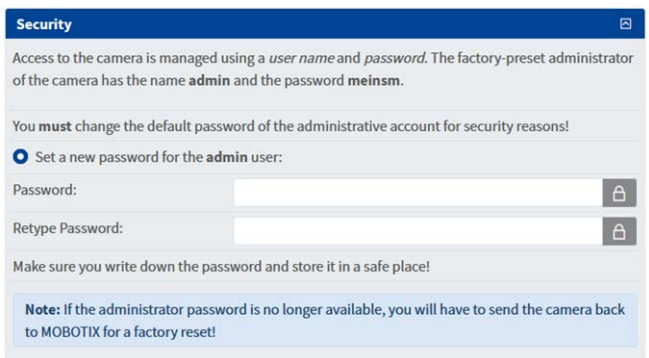

**NOTE!** Make sure to record the new password in the system documentation!

- Continue clicking on  and do not change any settings until you reach the **Country Settings** dialog. Check the time zone and adjust it, if necessary.

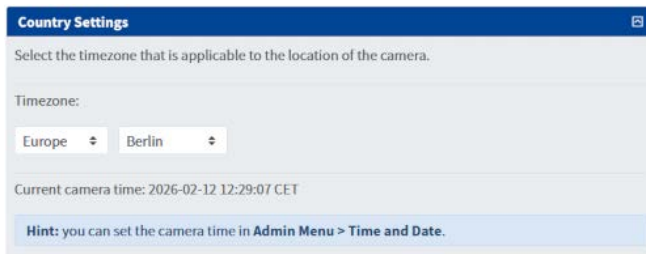

**Country Settings**

Select the timezone that is applicable to the location of the camera.

Timezone:

Europe Berlin

Current camera time: 2026-02-12 12:29:07 CET

**Hint:** you can set the camera time in **Admin Menu > Time and Date**.

- Click on  and in the **Audio Settings** dialog, activate the devices that are available for this camera.

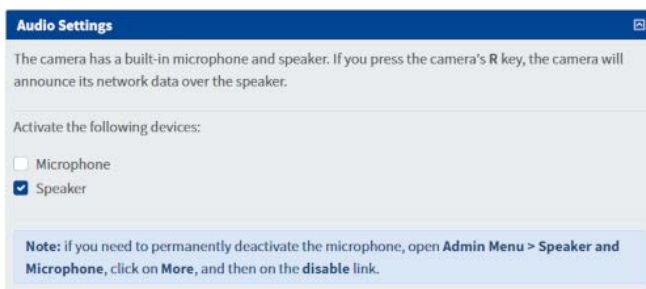

**Audio Settings**

The camera has a built-in microphone and speaker. If you press the camera's R key, the camera will announce its network data over the speaker.

Activate the following devices:

Microphone

Speaker

**Note:** If you need to permanently deactivate the microphone, open **Admin Menu > Speaker and Microphone**, click on **More**, and then on the **disable** link.

- Click on  and in the **Camera Name** dialog, enter a descriptive camera name.

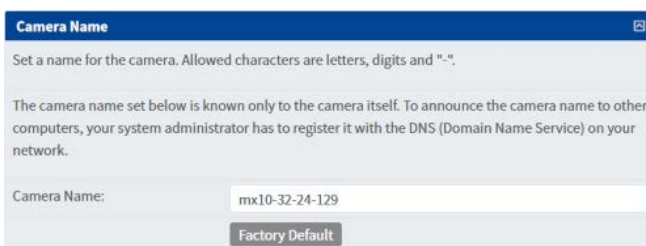

**Camera Name**

Set a name for the camera. Allowed characters are letters, digits and "-".

The camera name set below is known only to the camera itself. To announce the camera name to other computers, your system administrator has to register it with the DNS (Domain Name Service) on your network.

Camera Name: mx10-32-24-129

Factory Default

**NOTE!** Make sure to record this camera name in the system documentation!

- Continue clicking on  and do not change any settings until you reach the **Time Server** dialog. Enter the IP address of your network time servers as provided by your network administrator (e.g. 192.168.1.1 ptbtime1.ptb.de; use spaces to separate multiple addresses).

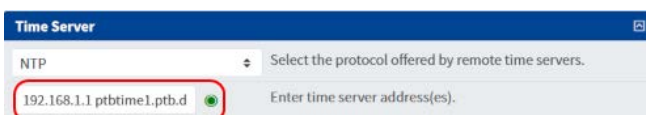

**Time Server**

NTP Select the protocol offered by remote time servers.

192.168.1.1 ptbtime1.ptb.de Enter time server address(es).

If the time server is working properly, the LED to the right of the field turns green. A red LED indicates that the server does not work properly.

## Operating the Camera

### Initial Camera Setup

---

- Click on  and review the information in the **Store Configuration** dialog. If everything is correct, print the page and include it in the system documentation.

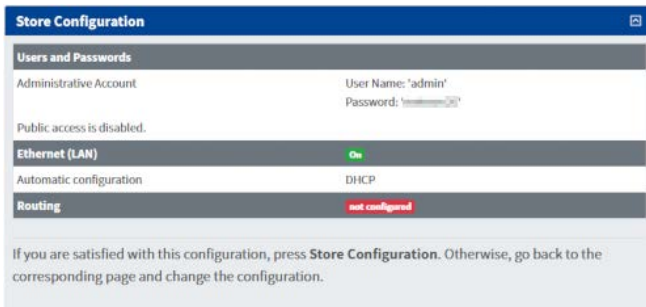

- Click on **Store Configuration** and then on **Reboot**.

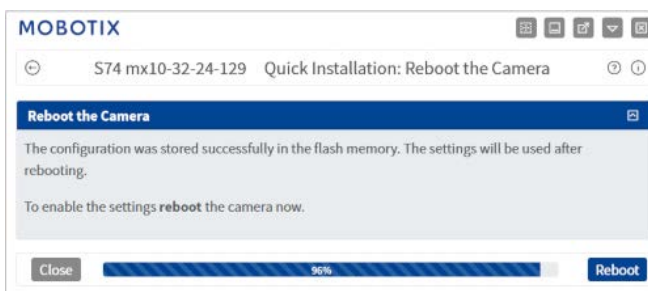

- Enter the new password you entered in the **Security** dialog when prompted by the camera. The camera will now reboot; once it is working again, you will see its live image.

## Find the "Real" IP Address of the Camera

Since you are still using the `mx10-32-24-129.local` zeroconf address, you need to find out the actual IP address of the camera.

1. Click on the **Show Camera Status** icon .
2. In the **Camera Status** dialog, click on **Networking**.
  - The **Camera Name** entry shows the camera's current fully qualified domain name.
  - The **BOOTP/DHCP** status *Client running, got a lease* shows that the camera properly received an IP address.
  - The **IP Address** entry shows the camera's current address.
3. You can use either the **Camera Name** (e.g. `mx10-32-24-129.fritz.box`) or the IP address (e.g. `192.168.1.210`) to access the camera from now on.
4. Open a new browser tab and enter the address (e.g. `mx10-32-24-129.fritz.box` or `192.168.1.210`), then enter the access credentials (`admin/<your new password>`).

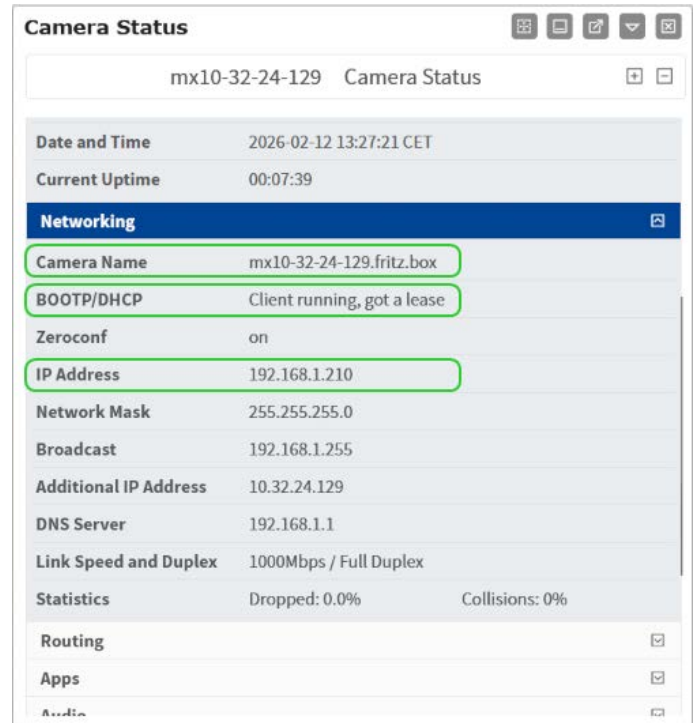

**NOTE!** Make sure to record this address in the system documentation together with the camera name!

## Network Settings on the Camera in MxMC

MxManagementCenter is a video management software for setting up and using the entire video surveillance system that provides a range of functions for different tasks and user groups. You can download the newest release of MxManagementCenter from the MOBOTIX website ([www.mobotix.com](http://www.mobotix.com) > Support > Download Center > Software Downloads, MxManagementCenter section).

When starting MxManagementCenter for the first time, the configuration wizard opens and automatically starts searching for MOBOTIX cameras. The number of found cameras is shown as a counter next to the **Add Devices** icon. This number is updated automatically if the number of MOBOTIX cameras on the network has changed (i.e., by connecting new/disconnecting existing cameras).

## Operating the Camera

### Initial Camera Setup



1. Click on **Add Devices**. The cameras are displayed either in a list or as tiles. Use the List and Tile buttons to change the display mode.

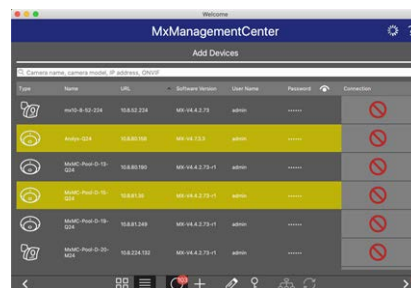

The application automatically monitors and displays the operating status of all cameras using corresponding icons.



#### EXAMPLE:

-  The camera is not in the same subnet as the computer.
-  The user name and password of the camera are not known.

#### NOTE!

Using the Bonjour service ([en.wikipedia.org/wiki/Bonjour\\_\(software\)](https://en.wikipedia.org/wiki/Bonjour_(software))), the application finds not only MOBOTIX cameras on the same subnet, but also in other subnets. Normally, you would not be able to establish any connection to cameras in a different network or subnet.

#### NOTE!

This is the case, for example, if you are integrating cameras into a network without DHCP server (i.e. with fixed IP addresses) and the IP address range is different from the 10.x.x.x range supported by the cameras in addition to DHCP.

MxManagementCenter can automatically configure such a camera so that it is "integrated" into your existing network.

2. Select the camera you want to set up and click on **Edit Network Settings**  at the bottom of the program window. The **Change Network Settings for Selected Devices** dialog opens.



3. Enter the IP address and the subnet mask of the selected camera.

**NOTE!**

The IP addresses of the other cameras are automatically incremented by 1.

4. Click on **Apply** to apply the settings.

**NOTE!**

For more information on this feature, please read the MxManagementCenter online help or the Tutorial (see [www.mobotix.com](http://www.mobotix.com) > Support > Download Center > Documentation > Brochures & Guides > Tutorials).

## Focusing the TELE 15° Sensor Module

Once the camera has been mounted, the **TELE 15° sensor module** should be checked for proper sharpness. You will need the **lens wrench M.2** and the **module wrench M.1** that are part of the [Scope of Delivery of the MOBOTIX S74 Base Module](#).

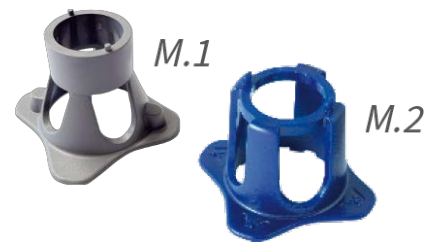

**CAUTION!**

When adjusting the image focus or the field of view of the camera, always make sure that you can see the live image of the camera on your monitor.

To correct image sharpness, you can also make use of the visual **focusing aid** of the camera (see the **Camera Reference Manual**, section **The Live View of the MOBOTIX Camera**)

1. Show the live image of the camera on your monitor.
2. Insert the lens wrench into the notches of the sensor module.
3. Turn the wrench counter-clockwise until it stops.



4. Rotate the wrench to the left until the lens protection glass slides out of the sensor module.

## Operating the Camera

### Focusing the TELE 15° Sensor Module

5. Insert the module wrench (with its two small pins) into the holes of the lens and cautiously turn to the left and to the right. Adjust the image sharpness according to the live image on the computer monitor:

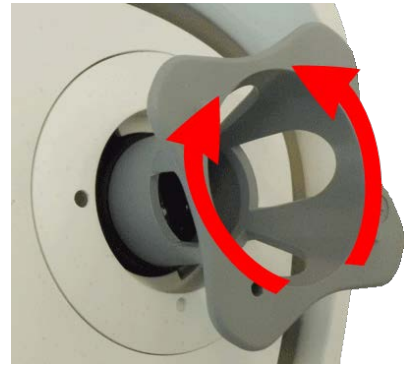

#### **CAUTION!**

Never apply force when turning the lens and never screw the lens too deep into the thread since this could damage the image sensor! If in doubt, keep turning the lens counter-clockwise, then turn clockwise to focus the lens.

6. If required, clean the inside of the lens protection glass with a clean, lint-free cloth.



7. Set the lens protection glass onto the notches of the lens wrench and position the protection glass with its two prongs over the corresponding receptacles of the sensor module:



- Using the lens wrench, press the lens protection glass firmly into the sensor module, until the glass fits flush with the sensor module housing.



- Turn the lens protection glass clockwise using the lens wrench until it locks in place.
- If required, clean the outside of the lens protection glass with a clean, lint-free cloth.

**CAUTION!**

After adjusting the focus, make sure that the sensor module is aligned properly and that it is locked in place (use the module wrench to turn the sensor module clockwise until it stops).



## Camera Software in the Browser

This section contains the following information:

<b>Access the Camera in the Web Browser</b> .....	<b>86</b>
<b>Basic Settings</b> .....	<b>87</b>
<b>Configuring Sensor Modules</b> .....	<b>88</b>

## Camera Software in the Browser

### Access the Camera in the Web Browser

The integrated software of the MOBOTIX S74 features a multitude of functions, such as video motion detection, long-term recording, alarm messaging and video IP telephony. Especially remarkable are the AI-based analytics features and the possibility to install third-party apps on the camera. Thanks to the virtual PTZ features, you can continuously zoom into or out of the live image using either the mouse wheel or a joystick.

When recording images or video sequences, you can choose to store either the visible image area of the live image or the full sensor image. This also allows examining the parts of an image or video that had not been visible in the real-time image section on display at the time of the recording.

Instead of using a web browser, you can also download the free MxManagementCenter from the MOBOTIX website ([www.mobotix.com](http://www.mobotix.com) > Support), which allows displaying multiple cameras on one monitor, allows for comfortably searching and evaluating the alarm video clips with audio and provides alerting features. For mobile iOS and Android devices, the free-of-charge MOBOTIX MOBOTIX LIVE App is available.

## Access the Camera in the Web Browser

Once the power and network connection of the MOBOTIX have been established, you can access the interface of the camera software in a web browser.

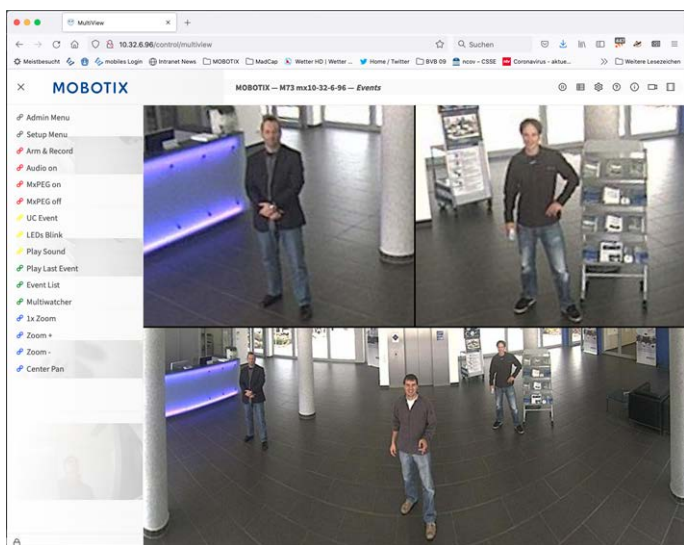

- Enter the camera's IP address in the address field of a web browser.

### NOTE!

You can find the IP address of the camera, for example, in the camera housing or on the sticker on the packaging.

# Basic Settings

**NOTE!**

You must change the password when logging in for the first time.

**CAUTION!**

Make sure that you store information on user names and passwords in a secure place.

If you lose the administrator password and cannot access the Administration menu, the password can only be reset at the factory. This service is subject to a service charge.

The Quick Installation Wizard will appear automatically when accessing the Administration Menu for the first time. It provides an easy method to adjust the basic camera settings to the current application scenario. For security reasons, it is highly recommended to change the default administrator password after the camera has been configured properly.

**Administering the camera:** You can modify the camera configuration in the Administration Menu or the Setup Menu:

- **Admin Menu:** This menu contains the basic configuration dialogs of the camera (e.g. passwords, interfaces, software update).
- **Setup Menu:** This menu contains the dialogs for configuring the image, event and recording parameters. Some of these settings can be changed using the corresponding Quick Controls in the Live screen.

**NOTE!**

For more information, consult the Reference Manual of the camera (see [www.mobotix.com](http://www.mobotix.com) > [Support](#) > [Download Center](#) > [Marketing & Documentation](#) > [User Manuals](#)).

# Configuring Sensor Modules

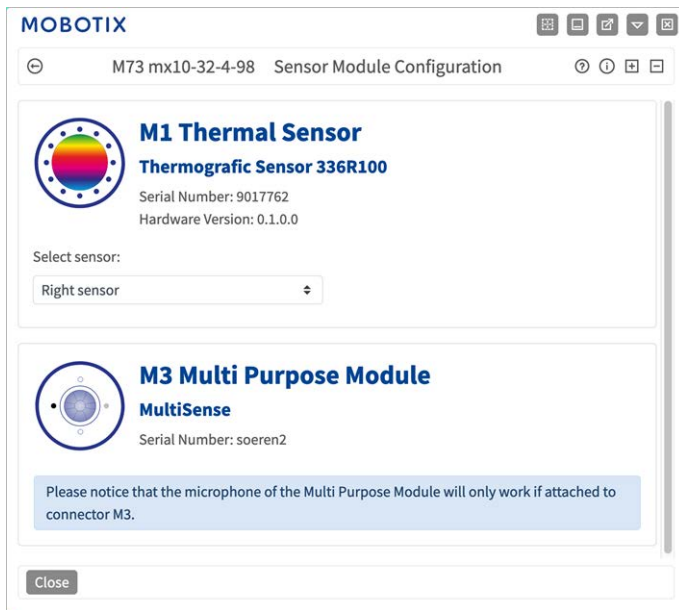

Using different combinations of sensor modules of the MOBOTIX S74 will have an influence on the display modes and configuration variants that are available.

An MOBOTIX S74 will automatically check and verify the installed sensor modules upon its first start and at every reboot thereafter (e.g., focal length, Day or Night variant). Please note the following:

- A Thermal Sensor Module , must be attached to connector **M1 (Thermal Sensor)**.
- If only one sensor module is attached, the camera will behave like a mono camera (i.e., there is no automatic Day/Night switching).
- If the modules are not exchanged within the first 12 operating hours, the camera will store the information of new sensor modules in the camera configuration.
- The camera will check the configuration on every reboot to see if the stored sensor modules are still present. If changes of the sensor module configuration have been detected (e.g., if a sensor module had to be replaced), the camera will show a corresponding message in the live image.

If required, the module configuration can be adjusted, e.g. you can define in which camera image (left or right) the sensor module should be displayed in a double image display.

1. Got to **Admin Menu > Hardware Configuration > Sensor Module Configuration**
2. Select the corresponding sensor module types

Do the **Sensor Module Configuration** in the following cases:

- **Switching the displayed camera images:** You want to show the left-hand camera image on the right (and vice versa), without having to physically swap the module connectors at the camera itself.

- **Exchanging sensor modules:** In this case, the MOBOTIX S74 will display a message box and will log a system message to inform you that sensor modules have been exchanged .
- **Adding/activating sensor modules:** You can activate modules that had been deactivated before.
- **Switching off/removing sensor modules:** If required, you can deactivate connected modules in this dialog.

For more information, consult the Reference Manual of the camera (see [www.mobotix.com](http://www.mobotix.com) > [Support](#) > [Download Center](#) > [Marketing & Documentation](#) > [User Manuals](#)).



## Maintenance

This section contains the following information:

<b>Cleaning the Camera and Lenses .....</b>	<b>92</b>
---	-----------

# Cleaning the Camera and Lenses

Clean the camera housing using a mild alcohol-free detergent without abrasive particles.

To protect the lens protection glass, only use the supplied mounting supplies.

## Cleaning the lens protection glass

- Use the wide end of the module wrench [M.1, p. 17](#) to remove/install the lens protection glass. The narrow side of the wrench is used to adjust the sharpness (focal length) of the tele lenses.
- You should clean the lens protection glasses and domes regularly using a clean, lint-free cotton cloth. If the dirt is more persistent, add a mild alcohol-free detergent without abrasive particles.
- Make sure you instruct cleaning personnel on how to clean the camera.

# MOBOTIX

BeyondHumanVision

[EN\\_04/26](#)

MOBOTIX AG • Kaiserstrasse • D-67722 Langmeil • Tel.: +49 6302 9816-103 • [sales@mobotix.com](mailto:sales@mobotix.com) • [www.mobotix.com](http://www.mobotix.com)

MOBOTIX is a trademark of MOBOTIX AG registered in the European Union, the U.S.A., and in other countries. Subject to change without notice. MOBOTIX do not assume any liability for technical or editorial errors or omissions contained herein. All rights reserved. © MOBOTIX AG 2020