



# Quick Installation

## MOBOTIX Mx-4IOA-Box

### Weatherproof Signal Input/Output

Connection of external sensors and switching of external devices via MOBOTIX cameras; connection to camera via USB cable.

- For MOBOTIX cameras with firmware MX-V7.3.4.x or higher
- 4 inputs for connecting sensors
- 4 relay outputs
- Protection class IP66, -30 to 65 °C/-22 to 149 °F
- Remote installation (max. 5 m/16.4 ft cable length)
- Complete set including mounting supplies



## Scope of Delivery

**Count Part Name**

1	Mx-4IOA-Box Order Code: Mx-F-4IOA
2	Stainless steel PZ head screws 4 x 40 mm
2	Stainless steel washers
2	Plastic dowels
1	Screwdriver, small, blue
4	Silicone rubber plugs, white
1	Silicone sealing ring for USB connector, black
2	Cable ties

---



# Installation Instructions

## NOTE!

- The MOBOTIX Mx-4IOA-Box is to be used only for providing signal inputs/outputs for MOBOTIX cameras in IP66 environments.
- For MOBOTIX cameras with software version MX-V7.3.4.x or higher.
- Make sure that you adhere to all relevant laws, regulations and that you fulfill all certification requirements for the intended use.
- Torque for cover screws: 0.4 Nm.
- Torque for fastening screws: 0.4 Nm.
- Press the white cable plug (eight-wire plug or cable plug 3 to 5 mm or 5 to 7 mm) into the casing in such a way that the rims stick out equally on both sides.
- Cross-sectional area of the signal wires: 0.6 to 0.8 mm<sup>2</sup>/AWG 26 to 20 (0.8 mm<sup>2</sup>/AWG 20 recommended to reduce line losses).

## Attach the box

Attach the Mx-4IOA-Box at the mounting position with the cable ports pointing downwards (max. torque 0.4 Nm). Next, remove the box cover (three screws).

## NOTE!

If you need a drilling template, please see [Dimensions/Drilling Template, p. 11](#).

## Connect the USB Cable

### Exchange Sealing of USB Connector

Since the opening in the Mx-4IOA-Box for the USB connector is wider than the installed sealing, you need to exchange the slim sealing ring of the connector by the supplied wider sealing ring.



1. Remove the slim sealing ring of the USB connector that will go into the Mx-4IOA-Box.
2. Identify the key of the USB connector (this must point to the outside of the box, not to the center when inserting later on).
3. Pull the delivered black sealing ring over the plug, so that the smaller opening points into the same direction as the plug's contacts.

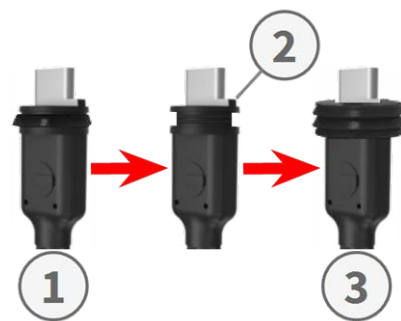

### Insert USB Connector Into Mx-4IOA-Box

1. Remove the blue bayonet catch of the Mx-4IOA-Box and pull out the blue plug.
2. Plug the USB connector with attached sealing ring into the Mx-4IOA-Box and make sure that the key is pointing to the outside of the box, not to the center.
3. Secure the connector using the blue bayonet catch.



**NOTE!**

Please refer to the corresponding *Quick Installation* guide on how to connect the USB cable to the MOBOTIX camera.

## Connect the peripheral devices

Connect the other wires/cables as required and by using the corresponding cable plugs (inputs, outputs).

- IN (inputs 1 to 4): N = negative, P = positive
- OUT (outputs 1 to 4): wires A and B

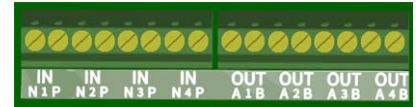

## Mount the cover



Mount the cover back onto the Mx-4IOA-Box and attach it using the cover screws (torque 0.4 Nm).

## Initializing the Mx-4IOA-Box

### Open the MOBOTIX camera's user interface in the browser

- Enter the IP address of the camera that is connected to the Mx-4IOA-Box in the browser (admin access rights required):  
`http://<camera IP address>`
- Click on the ☰ menu icon in the Live screen of the camera.
- Open **Admin Menu > Network Setup > Ethernet Interface**.
- If **Power Supply** has not been set to *Power over Ethernet (Class 3)*, click on the **Change** link, follow the steps of the wizard and activate *Power over Ethernet (Class 3)*.
- Open **Admin Menu > Hardware Configuration > Manage Hardware Expansions**.
- In the **USB Connector** section, click on the **Connect** button in the **Mx-4IOA-Box USB** row.
- After about 15 to 20 seconds, the status changes to *New device(s) available*, the **Device Type** shows *IO Module* with the status **Addressable** in the **Devices** section.

### Configure events of the signal inputs and outputs

- Click on the ☰ menu icon in the Live screen of the camera.
- Open **Setup Menu > Event Control > Event Overview**.
- In the **Signal Events** section, click on **Edit** and set the parameters as required (open the help page for this dialog by clicking on .
- You can now use the new events in the **Setup Menu > Event Control > Action Group Overview** dialog (open the help page for this dialog by clicking on .

## Store the camera configuration

- Click on the ☰ menu icon in the Live screen of the camera.
- Open **Admin Menu > Configuration > Store** and permanently store the camera configuration on the camera (no reboot necessary).
- Open **Admin Menu > Configuration > Save** and save the camera configuration to the local computer. This will allow you to load the configuration when replacing the camera, for example.

## USB Cables

**NOTE!**

- Only use MOBOTIX USB cables for connecting the Mx-4IOA-Box to a MOBOTIX camera! Using cables without integrated sealing will lead to moisture damaging the attached devices!
- USB cables are not part of the delivery and are to be ordered separately!

**MX-CBL-MUC-MU-1/5**

**Mx-CBL-MUC-AN-MU-1/5**

**Mx-A-S7A-CBL02/03**

**Mx-A-S7A-CBL01/02/03-  
AN**



USB-C straight to Mini  
USB straight

USB-C angled to Mini USB  
straight

USB-C straight to USB-C  
straight

USB-C straight to USB-C  
angled

1 or 5 m/3.3 or 16.4 ft

1 or 5 m/3.3 or 16.4 ft

2 or 3 m/6.6, or 9.9 ft

1, 2, or 3 m/3.3, 6.6, or 9.9  
ft

## LED Signals

LED	Meaning
<b>Operation</b> (left)	<input type="checkbox"/> Not connected
	<input checked="" type="checkbox"/> Regular operation
	<input checked="" type="checkbox"/> Communication error
<b>I/O Status</b> (right)	<input checked="" type="checkbox"/> 1x: Output 1 closed
	<input checked="" type="checkbox"/> 2x: Output 2 closed
	<input checked="" type="checkbox"/> 3x: Output 3 closed
	<input checked="" type="checkbox"/> 4x: Output 4 closed
	<input checked="" type="checkbox"/> 1x: Input 1 closed
	<input checked="" type="checkbox"/> 2x: Input 2 closed
	<input checked="" type="checkbox"/> 3x: Input 3 closed
	<input checked="" type="checkbox"/> 4x: Input 4 closed



### LED Signaling Patterns

<input checked="" type="checkbox"/>	On
<input type="checkbox"/>	Off
<input checked="" type="checkbox"/>	Short flashing
<input checked="" type="checkbox"/>	50% on, 50% off (regular flashing)

## Signaling Patterns for Several Inputs/Outputs

When several inputs or outputs are closed, a little pause will separate the signals.

## Quick Installation

### MOBOTIX Mx-4IOA-Box

---

#### **EXAMPLE:**

**Inputs 1 and 3 as well as outputs 2 and 4 are closed.**

The right LED will flash with this pattern:

- 1x flash green
- Pause
- 3x flash green
- Pause
- 2x flash blue
- Pause
- 4x flash blue
- Pause, then repeat

## Dimensions/Drilling Template

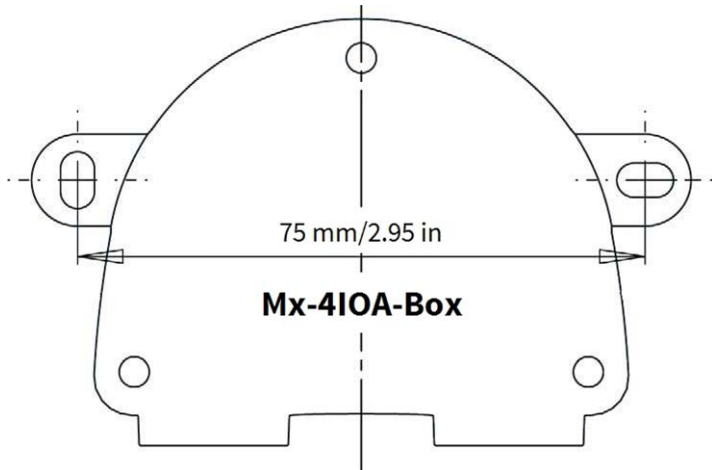

Fig. 1: Mx-4IOA-Box: All measurements in mm

**NOTE!**

When printing this page at 100% of the original size (no scaling) you can use this page as drilling template.

# Technical Specifications

## Mx-F-4IOA

Inputs	4 galvanically separated inputs, self powered, up to 30 Vrms AC / 50V DC Switching thresholds: <ul style="list-style-type: none"><li>▪ Input &gt;1.6V leads to a detected HIGH</li><li>▪ Input &lt;0.9V leads to a detected LOW (after a high)</li></ul> max. length for cables: 50m	
Outputs	4 Form A relay contacts (max 30 Vrms AC / max, 50V DC/ 60 W/ 2A DC)	
Wire specifications (terminals)	<i>Conductor cross section</i>	
	AWG	20 - 26
	Rigid	0.14mm <sup>2</sup> - 0.8mm <sup>2</sup>
	Flexible	0.14mm <sup>2</sup> - 0.5mm <sup>2</sup>
	Flexible with ferrule	0.25mm <sup>2</sup> - 0.34mm <sup>2</sup>

## General Hardware Specifications

Power consumption	Typ. 100 mW, max 700 mW
Protection class	IP66
Operating temperature	-30 to 65 °C/-22 to 149 °F
Certificates	CE, EMC, ROHS, AS/NZS CISPR 32, 47 CFR FCC Part 15, Subpart B, Class A, ICES-003 Class A, EN 54-18 FM 3260, ANSI/FM 3260

---

Dimensions (width x height x depth)	86 x 56 x 31 mm/3.39 x 2.20 x 1.22 in (without rubber plugs)
--	---

Weight	70 g
--------	------

---

# MOBOTIX

BeyondHumanVision

EN\_06/26

MOBOTIX AG • Am Stundenstein 2 • D-67722 Winnweiler • Tel.: +49 6302 9816-103 • sales@mobotix.com • www.mobotix.com  
MOBOTIX is a trademark of MOBOTIX AG registered in the European Union, the U.S.A., and in other countries. Subject to change without notice. MOBOTIX do not assume any liability for technical or editorial errors or omissions contained herein. All rights reserved. © MOBOTIX AG 2024