

MOBOTIX

BeyondHumanVision



FM
APPROVED
ANSI/FM 3260

Whitepaper

See the Threat Before the Fire Starts.

How Early Thermal Image Fire Detection Is Changing Industrial Fire Protection – Featuring the MOBOTIX M73 Thermal FM Bundle

ANSI/FM3260-Approved Thermal Image Fire Detection for Operational Continuity, Early Risk Visibility, and Industrial Resilience

Blueprint for Industrial Operators, Consultants, Integrators & Fire Protection Specialists

v1.0

2026-06-03

Table of Contents

1	Executive Summary	3
2	Industrial Fire Risks Are Changing	4
3	The Limits of Conventional Detection	6
4	The Rise of Preventive Thermal Fire Detection	7
5	Why ANSI/FM 3260 Approval Matters	8
6	Introducing the MOBOTIX M73 Thermal FM Bundle	9
7	Designed for Operational Visibility	13
8	Defined Risk Zone Monitoring	14
9	Cybersecurity Matters	15
10	Operational Continuity Is the Real Goal	16
11	Typical Industrial Applications	17
12	Insurance, Risk Reduction & Long-Term Economics	19
13	Integration Into Modern Operations	20
14	Preventive Fire Protection Requires a New Mindset	21
15	Conclusion	22
16	Legal Disclaimer	23
17	Contact information	23

1 Executive Summary

Industrial fire protection is entering a new phase.

Across industries such as recycling, battery manufacturing, logistics, biomass processing, and heavy industry, operators are facing a growing reality: many of today's most critical fire risks begin long before visible smoke or flames appear.

At the same time, the consequences of industrial fire events have become significantly more severe. For many organizations, the greatest financial impact is no longer limited to physical fire damage itself. Production interruption, downtime, disrupted supply chains, damaged customer relationships, environmental exposure, and prolonged recovery periods increasingly represent the larger business risk.

This shift is fundamentally changing how industrial organizations think about fire protection.

Traditional detection technologies remain essential and highly effective in many applications. However, modern industrial risk environments increasingly require earlier operational visibility into developing thermal anomalies before escalation reaches visible combustion stages.

This is particularly relevant in environments where heat buildup develops internally, thermal runaway can occur unexpectedly, or environmental conditions challenge conventional detection systems. In many industrial applications, smoke appears late, flames become visible only during advanced escalation stages, and operational damage may already be underway before traditional systems react.

Preventive Thermal Image Fire Detection introduces an additional operational layer designed to address this challenge. Instead of waiting for smoke or visible flames, thermal imaging systems continuously monitor temperature development and identify abnormal heat patterns earlier in the escalation process. This allows organizations to detect thermal risk before disruption spreads across operations.

The MOBOTIX M73 Thermal FM Bundle combines FM-approved Thermal Image Fire Detection with operational visibility, industrial integration, cybersecurity, and decentralized edge-based processing in a unified industrial platform architecture.

The result is not simply earlier fire detection. It is earlier operational awareness, reduced downtime exposure, and improved business resilience.

2 Industrial Fire Risks Are Changing

Industrial fire risks are becoming more complex.

Several developments are accelerating this shift simultaneously. Lithium-ion batteries are rapidly transforming industries such as electric mobility, energy storage, logistics, manufacturing, recycling, and consumer electronics. At the same time, these environments introduce highly challenging thermal-risk scenarios that behave differently from traditional industrial fire patterns.

Thermal runaway can begin internally and escalate rapidly. In many cases, dangerous heat development occurs long before visible smoke or flames appear. By the time conventional systems react, operational damage may already be spreading through production environments, storage areas, or logistics infrastructure.



This creates significant challenges for industrial operators.

Battery manufacturing facilities, recycling operations, charging infrastructure, temporary storage areas, and logistics environments increasingly require earlier visibility into abnormal thermal behavior before escalation disrupts operations or creates catastrophic damage.

The same development can be observed across the waste and recycling industry. Worldwide, recycling facilities have become one of the fastest-growing industrial fire risk categories. Hidden lithium-ion batteries inside waste streams, constantly changing material accumulations, dust, airflow, moving equipment, self-heating materials, and outdoor storage conditions create highly dynamic thermal-risk environments that are difficult to monitor with conventional approaches alone.

For operators, the consequences can be severe.

A single fire event may lead to operational shutdowns, damaged infrastructure, environmental exposure, insurance complications, supply chain disruption, customer impact, and long-term reputational

damage. In many industries, recovery periods after major fire incidents can extend far beyond the immediate physical event itself.

As a result, industrial organizations are increasingly shifting from reactive fire detection toward preventive thermal-risk monitoring strategies designed to identify abnormal heat development earlier in the escalation process.

At the same time, operational continuity has become a major strategic driver behind fire protection investments.

Modern industrial facilities depend on continuous production, automated workflows, uninterrupted material flow, and tightly coordinated logistics processes. Even relatively small thermal incidents can trigger production interruptions, equipment damage, missed delivery obligations, operational bottlenecks, and extended downtime exposure.

For many organizations, the real financial risk is no longer only the fire itself. It is the interruption of operations.

This is fundamentally changing how industrial operators evaluate fire protection technologies. The question is no longer limited to how a fire can be detected. Increasingly, organizations are asking how early thermal risk can become visible before escalation impacts production, logistics, or operational continuity.

Operational Impact of Industrial Fire Events

- Production downtime
- Supply chain disruption
- Equipment damage
- Environmental exposure
- Insurance complications
- Reputation loss
- Customer delivery delays
- Regulatory investigations

In FM-driven environments, this shift is becoming even more important. Industrial insurers, consultants, and engineering firms increasingly evaluate thermal-risk management as part of broader operational risk strategies. FM-approved technologies can influence project approvals, specification acceptance, insurer confidence, and long-term operational resilience planning.

Preventive thermal monitoring is therefore increasingly viewed not only as a safety investment, but also as part of a larger operational continuity and risk-reduction strategy.

3 The Limits of Conventional Detection

Traditional fire detection technologies remain essential components of modern fire protection.

However, every technology operates within environmental and operational limitations. Smoke detection systems are highly effective in many controlled indoor applications, but performance can become more challenging in environments with dust, airflow, open industrial spaces, or constantly changing operational conditions. Large industrial halls, recycling facilities, outdoor zones, and dynamic production environments often create conditions where smoke behavior becomes less predictable.

Flame detection technologies provide rapid response once visible combustion characteristics already exist. However, by definition, flame detectors react after visible escalation has already begun. In many industrial environments, operators increasingly want earlier visibility into dangerous thermal development before flames become visible.

Heat detection systems remain reliable and proven technologies, but large industrial environments often require broader situational visibility across multiple operational areas and evolving risk zones. This is where Preventive Thermal Image Fire Detection introduces a fundamentally different operational perspective.

Instead of reacting primarily to visible combustion, thermal imaging systems continuously monitor heat development itself. This allows organizations to identify abnormal thermal behavior before smoke or visible flames appear and before escalation spreads across operations.

Technology	Strengths	Limitations in Industrial Environments
Smoke Detection	Proven indoor detection	Dust, airflow, large open spaces
Flame Detection	Fast visible flame response	Reacts after visible combustion
Heat Detection	Reliable threshold monitoring	Limited situational visibility
Thermal Imaging	Early thermal anomaly detection	Requires proper configuration & operational integration

That difference can be operationally significant.

Earlier thermal visibility can support faster intervention, improved situational awareness, reduced downtime exposure, and greater operational control during developing thermal-risk situations.

The objective is not to replace every conventional detection technology. The objective is to expand visibility earlier into the escalation process.

4 The Rise of Preventive Thermal Fire Detection

Preventive Thermal Image Fire Detection introduces a new layer of operational intelligence into industrial fire protection.



Instead of focusing only on visible combustion products such as smoke or flames, thermal imaging systems continuously analyze surface temperatures, thermal behavior, and abnormal heat development across defined operational areas.

This creates the possibility to identify escalating thermal conditions before visible fire development occurs.

In many industrial environments, this distinction is critical.

Materials can self-ignite internally. Heat buildup may develop gradually over time. Thermal runaway events can escalate unpredictably. In some cases, smoke appears only during advanced escalation stages, while visible flames may emerge only after operational damage has already begun.

Thermal imaging systems help organizations gain earlier visibility into these evolving conditions. Rather than waiting for visible escalation, operators can monitor hotspots, abnormal heat patterns, self-heating processes, and developing thermal anomalies in real time. This supports earlier operational intervention before situations evolve into larger fire events.

As industrial environments become more complex, preventive thermal monitoring is increasingly becoming part of broader operational resilience strategies focused on reducing disruption, improving response coordination, and protecting long-term business continuity.

5 Why ANSI/FM 3260 Approval Matters

Factory Mutual approvals play a major role in industrial fire protection projects, particularly throughout North America.



For many industrial operators, consultants, insurers, and engineering firms, FM-approved technologies represent more than technical compliance alone. They support operational confidence in environments where downtime exposure, asset protection, and long-term resilience have become critical business priorities.

In FM-driven industrial environments, approved technologies can significantly influence project approvals, engineering specifications, insurability, and broader operational risk-management strategies. As industrial fire risks continue to evolve, preventive thermal monitoring technologies are becoming increasingly relevant within modern industrial protection concepts. Organizations are no longer focused exclusively on reacting to visible fire events. Increasingly, they are seeking earlier visibility into developing thermal risks before escalation impacts operations.

The **MOBOTIX M73 Thermal FM Bundle** combines ANSI/FM 3260-approved Thermal Image Fire Detection with preventive operational visibility designed for demanding industrial environments. This allows organizations to integrate earlier thermal-risk awareness into broader operational continuity and resilience strategies aimed at reducing downtime exposure and catastrophic operational loss.

ANSI/FM 3260 approval therefore supports more than compliance requirements. It helps create confidence in environments where operational continuity matters.

6 Introducing the MOBOTIX M73 Thermal FM Bundle

The MOBOTIX M73 Thermal FM Bundle is an FM 3260-approved Thermal Image Fire Detection solution designed for modern industrial risk environments where early thermal visibility is operationally critical.

The system helps organizations identify abnormal temperature development before escalation leads to visible smoke, flames, equipment damage, production disruption, or catastrophic fire events.

Unlike many traditional fire detection approaches, the MOBOTIX architecture combines preventive thermal monitoring, operational visibility, industrial IP integration, cybersecurity, and decentralized edge-based processing within a unified platform architecture designed for industrial scalability. Thermal analysis and event handling are processed directly at the edge, reducing dependency on centralized analytics infrastructures while supporting flexible deployment concepts across complex industrial environments.

The system is designed for applications such as recycling facilities, battery manufacturing and recycling, logistics operations, conveyor systems, biomass storage, outdoor industrial areas, heavy manufacturing environments, and critical infrastructure applications where earlier thermal visibility can significantly improve operational awareness.

MOBOTIX M73 Thermal FM Bundle

- ANSI/FM 3260-approved
- Preventive thermal anomaly detection
- Edge-based decentralized processing
- IP-native industrial integration
- Visual thermal situational awareness
- ONVIF, MQTT, SNMP, Modbus TCP support
- Cybersecure architecture
- Designed for harsh industrial environments



Scope of Delivery M73 FM Bundle

Unlike many fire detection solutions that require extensive component sourcing, engineering effort, and system integration, the MOBOTIX M73 Thermal FM Bundle is delivered as a complete, pre-configured solution package designed specifically for ANSI/FM 3260-compliant Thermal Image Fire Detection applications. The bundle combines all essential hardware components required for thermal monitoring, alarm signaling, and FM-compliant system integration in a single solution architecture.

The M73 FM Bundle includes:

- Pre-configured MOBOTIX M73 camera with Thermal Radiometry sensor
- Integrated multisensor module
- FM-approved Mx-F-4IOA interface box for alarm and status signaling
- FM-approved Mx-F-NPAA network and power interface box
- USB connection cable between camera and I/O module
- Mounting accessories and installation hardware

Together, these components create a ready-to-deploy thermal detection platform that significantly reduces installation complexity compared to traditional multi-vendor fire detection architectures.

Purpose-Built for FM 3260 Applications

The system architecture has been specifically designed to support ANSI/FM 3260 fire detection projects while maintaining the flexibility expected from a modern IP-based industrial platform.

The M73 Thermal Radiometry camera continuously monitors temperature development across configurable measurement areas. Thermal analysis is performed directly at the edge, allowing abnormal heat patterns, hotspots, and temperature escalation to be detected without requiring centralized analytics servers.

The included interface modules provide dedicated alarm paths for:

- Pre-Alarm
- Alarm
- Malfunction / System Fault

This allows the system to be integrated directly into existing fire alarm panels, operational monitoring systems, or industrial automation environments while preserving clear alarm escalation paths.

Simple Installation, Fast Deployment

One of the key advantages of the MOBOTIX M73 Thermal FM Bundle is its straightforward installation concept.

Unlike many traditional fire detection systems that require multiple detectors, separate control units, dedicated analytics hardware, and extensive field wiring, the MOBOTIX architecture is based on a small number of tightly integrated components.

The camera connects directly to the FM-approved interface modules. Alarm outputs, network connectivity, and power supply are handled through the included connection architecture.

This reduces:

- Installation effort
- Wiring complexity
- Integration time
- Commissioning effort
- Long-term maintenance requirements

For many projects, deployment can be completed significantly faster than with conventional fire detection architectures while still providing advanced thermal monitoring and operational visibility.

Typical System Architecture

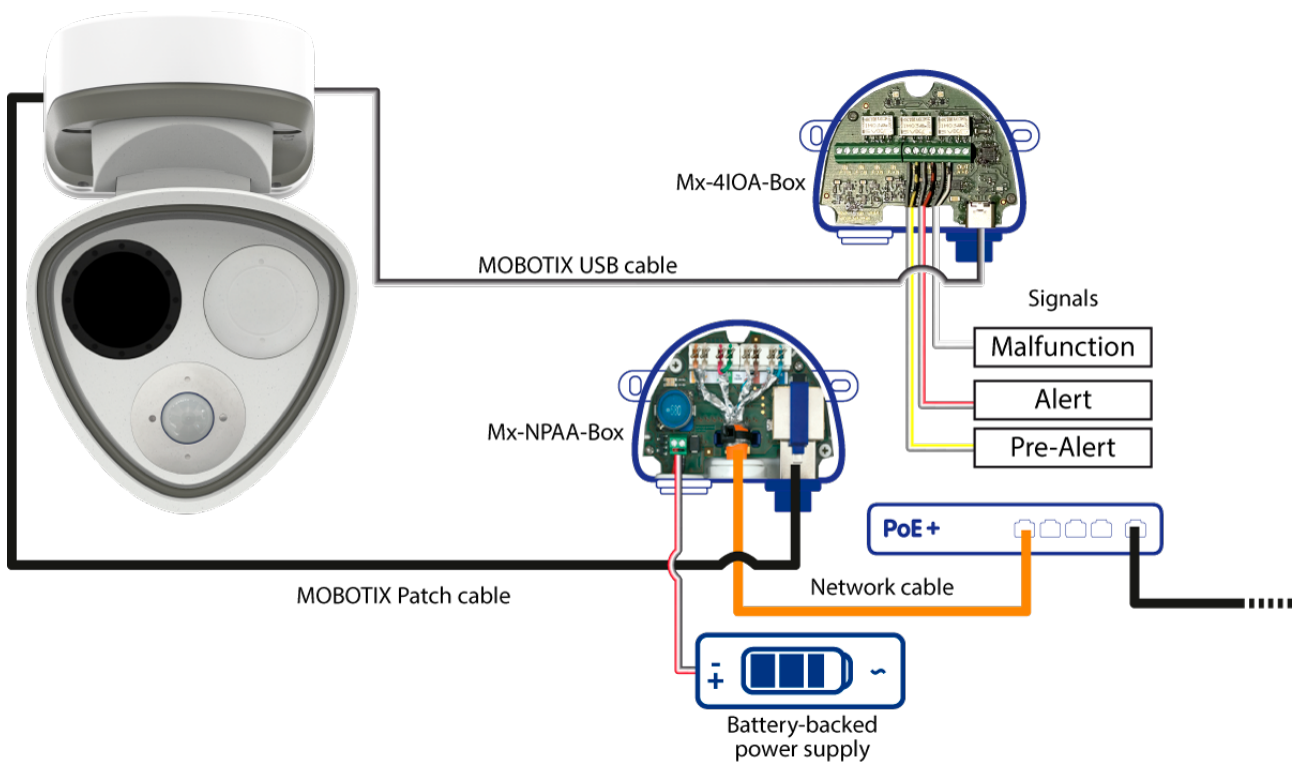

Simplified Wiring Architecture of the MOBOTIX M73 Thermal FM Bundle

The wiring architecture illustrates the simplicity of the overall system design. The M73 Thermal Camera communicates directly with the FM-approved Mx-F-4IOA interface module via USB connection. The Mx-F-NPAA module provides network connectivity and monitored power supply functions.

Dedicated outputs are available for:

- Pre-Alarm notification
- Alarm activation
- System malfunction reporting

The architecture supports integration into Fire Alarm Control Panels (FACP), industrial monitoring systems, SCADA environments, video management platforms, and other operational infrastructures.

Integration Into Existing Operations

Beyond fire detection itself, the MOBOTIX M73 Thermal FM Bundle is designed to become part of a broader operational ecosystem. Through open communication standards including ONVIF, MQTT, SNMP and Modbus TCP, the platform can be integrated into existing fire protection systems, operational monitoring platforms, industrial control environments, MOBOTIX HUB and third-party video management systems. This allows organizations to incorporate preventive thermal monitoring into existing operational workflows without creating isolated subsystems.

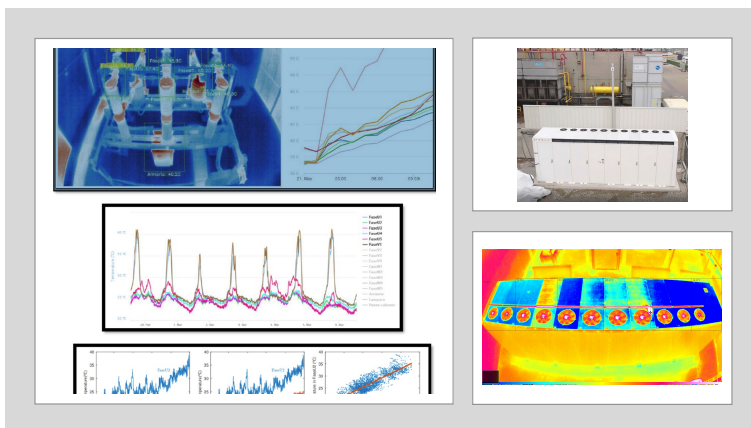

More Than an Alarm

Unlike conventional detectors that simply signal an alarm event, the MOBOTIX platform provides visual verification, configurable monitoring zones, and real-time thermal situational awareness. Operators can see where abnormal temperature development

occurs, assess escalation patterns, and make faster operational decisions before disruption spreads across the facility. The combination of thermal measurement, visual verification, and intelligent alarm escalation enables a more informed and effective response to developing thermal incidents.

The result is not simply earlier fire detection. It is improved operational awareness, reduced downtime exposure, and stronger operational resilience.

7 Designed for Operational Visibility

One of the most important advantages of Thermal Image Fire Detection is operational visibility.

Traditional fire detection systems often provide alarm notifications only after predefined thresholds have already been reached. In many industrial environments, however, operators require more than a simple alarm event. They need contextual awareness and earlier visibility into developing thermal situations before escalation impacts operations.

Thermal imaging introduces an additional operational layer by combining automated alarms with real-time thermal intelligence and visual situational awareness.

Instead of reacting to a single alarm point, operators gain visibility into how thermal conditions are developing across operational environments. Hotspots, abnormal heat buildup, escalating thermal patterns, and developing anomalies can be localized earlier and assessed more effectively.

This visibility can significantly improve response coordination in environments with moving materials, complex production workflows, conveyor systems, outdoor operational zones, or constantly changing risk conditions.

Rather than functioning solely as a detection mechanism, Preventive Thermal Image Fire Detection becomes part of a broader operational continuity strategy focused on earlier awareness and faster operational decision-making.

8 Defined Risk Zone Monitoring

Industrial thermal risks rarely develop uniformly across an entire facility.



Specific operational areas often represent elevated thermal-risk zones depending on production processes, material flows, storage configurations, or environmental conditions. Conveyor transfer points, battery storage zones, material accumulation areas, machinery sections, and outdoor storage environments frequently require more focused monitoring strategies than surrounding operational areas.

The MOBOTIX M73 Thermal FM Bundle supports configurable Measurement Areas that allow organizations to define monitoring zones according to operational requirements and evolving risk profiles.

This flexibility is particularly valuable in industrial environments where layouts, storage conditions, or production workflows may change over time. Instead of applying identical monitoring logic across an entire facility, operators can align thermal monitoring strategies more closely with actual operational risk conditions.

The ability to adapt monitoring dynamically helps improve operational visibility and supports more targeted response coordination during developing thermal events.

9 Cybersecurity Matters

Industrial fire protection systems are becoming increasingly connected to enterprise IT environments, operational technology networks, remote operational infrastructures, and centralized monitoring platforms.

As industrial connectivity increases, cybersecurity becomes a critical component of operational resilience.

Key Cybersecurity Capabilities

- Signed firmware
- SSL/TLS encryption
- VPN support
- IEEE 802.1X
- User & role management
- Secure edge processing
- No cloud dependency

The MOBOTIX platform supports multiple cybersecurity capabilities, including signed firmware, SSL encryption, user and group management, VPN support, IEEE 802.1X, and secure IP integration. This is particularly important for critical infrastructure operators, industrial manufacturers, logistics organizations, energy providers, and enterprises with strict IT and operational security requirements.

Unlike historically isolated fire protection systems, modern industrial environments increasingly require secure integration into broader enterprise infrastructures. The decentralized MOBOTIX architecture supports this transition through edge-based processing concepts and secure-by-design principles that reduce dependency on centralized cloud processing.

As industrial IT and OT (Operational Technology) environments continue to converge, cybersecurity is becoming more than an IT consideration alone. It is increasingly part of long-term operational risk management.

10 Operational Continuity Is the Real Goal

In many industrial sectors, operational continuity has become just as important as fire detection itself.

A fire event rarely impacts only one isolated system. Even limited thermal incidents can quickly trigger cascading operational consequences across production, logistics, customer commitments, workforce safety, environmental compliance, and supply chain operations.

For many organizations, the largest financial exposure is no longer limited to physical fire damage alone. The larger business risk is operational interruption.

Production downtime, damaged workflows, disrupted logistics, missed deliveries, and extended recovery periods can create operational and financial consequences that continue long after the original event has been resolved.

Preventive Thermal Image Fire Detection helps organizations shift from reactive emergency response toward proactive operational risk management.

The earlier abnormal heat development becomes visible, the greater the opportunity to isolate risk areas, stop material movement, intervene operationally, protect assets, and reduce escalation before disruption spreads across operations.

For many industrial operators, the real value is therefore not only preventing fire. It is protecting operational continuity and reducing business disruption exposure.

11 Typical Industrial Applications

Preventive Thermal Image Fire Detection is particularly valuable in environments where thermal risks may develop gradually, internally, or under operational conditions that challenge conventional detection approaches.

Industry	Typical Thermal Risks
Recycling	Hidden Li-ion batteries
Battery Storage	Thermal runaway
Biomass	Self-heating hotspots
Logistics	Conveyor-based escalation
Heavy Industry	Machinery overheating

Waste and recycling facilities represent one of the most important examples. Hidden lithium-ion batteries inside waste streams, mixed materials, dust, constantly changing storage conditions, and moving operational environments create highly dynamic thermal-risk scenarios. Thermal monitoring helps organizations identify abnormal heat development earlier before escalation impacts operations.



Battery manufacturing and recycling environments present similar challenges. Dangerous thermal escalation processes can develop internally before visible smoke or flames appear. Preventive thermal monitoring provides earlier visibility into abnormal heat buildup associated with damaged cells, thermal runaway scenarios, or high-density battery storage conditions.

Biomass and wood-storage environments can experience internal self-heating processes over extended periods of time. Thermal monitoring helps operators identify developing hotspots and escalating temperature anomalies earlier before combustion stages become visible.

Conveyor systems introduce additional operational complexity because thermal risks can move dynamically across multiple operational zones within a facility. Monitoring **transfer points, receiving zones, and material accumulation areas** helps improve localization and operational response coordination.

Large outdoor industrial environments can also challenge conventional smoke detection approaches due to airflow, environmental conditions, and open operational layouts. Thermal imaging provides continuous visibility across large operational areas where traditional detection technologies may become less effective.



12 Insurance, Risk Reduction & Long-Term Economics

Industrial fire events often create long-term financial consequences that extend far beyond immediate physical damage.

In many industries, the largest business impact is increasingly linked to operational interruption, production recovery, environmental exposure, customer disruption, insurance implications, and extended downtime.

As industrial thermal risks continue to evolve, organizations and insurers are increasingly focusing on preventive risk-reduction strategies instead of relying solely on reactive emergency response concepts.

This is particularly relevant in industries such as recycling, battery handling, biomass storage, logistics, warehousing, and heavy manufacturing where operational continuity plays a critical role in long-term business performance.

As a result, the evaluation of fire protection technologies is increasingly shifting beyond compliance requirements alone.

Long-Term Operational Benefits

- Reduced downtime exposure
- Earlier operational intervention
- Improved situational awareness
- Faster response coordination
- Lower business interruption risk
- Enhanced operational resilience

Industrial organizations are increasingly focused on reducing operational risk exposure, improving resilience, minimizing downtime potential, and protecting long-term business continuity.

Preventive Thermal Image Fire Detection supports this shift by helping organizations identify abnormal thermal behavior earlier in the escalation process and increasing the opportunity for operational intervention before severe disruption occurs.

For many organizations, preventive thermal monitoring is therefore becoming part of a broader operational continuity and long-term resilience strategy.

13 Integration Into Modern Operations

Modern industrial facilities increasingly require integrated operational environments where fire protection, operational monitoring, security systems, and industrial control infrastructures can interact more efficiently.

As industrial operations become more connected, organizations are moving away from isolated subsystem architectures toward unified operational visibility strategies.

The MOBOTIX architecture supports integration into fire alarm systems, video management platforms, industrial control systems, monitoring infrastructures, and operational dashboards through open communication standards and industrial IP connectivity.

This allows Preventive Thermal Image Fire Detection to become part of broader industrial workflows instead of functioning solely as an isolated detection subsystem.

The ability to integrate preventive thermal monitoring directly into existing operational infrastructures can improve centralized visibility, support faster operational coordination, and simplify thermal-risk management across complex industrial environments.

14 Preventive Fire Protection Requires a New Mindset

The future of industrial fire protection is not about replacing every conventional detection technology.

It is about expanding visibility earlier into the escalation process.

In many industrial environments, reactive fire detection alone may no longer provide sufficient operational awareness into developing thermal risks. Organizations increasingly require earlier insight into dangerous temperature development before smoke or visible flames appear.

Preventive Thermal Image Fire Detection introduces an additional operational layer focused on identifying escalating thermal conditions earlier and supporting faster operational intervention before disruption spreads across operations.

Instead of waiting for visible combustion, operators gain earlier visibility into abnormal heat development, thermal anomalies, self-heating processes, and developing operational risks that may otherwise remain hidden until advanced escalation stages.

This can improve operational awareness, response coordination, asset protection, downtime reduction, and long-term business continuity.

The shift is therefore no longer only about detecting fire events. It is about identifying thermal risk earlier and reducing operational impact before escalation occurs.

15 Conclusion

Industrial fire risks are evolving.

Many modern industrial environments now require earlier visibility into abnormal temperature development long before visible smoke or flames appear.

The MOBOTIX M73 Thermal FM Bundle introduces an FM 3260-approved, IP-native approach to Preventive Thermal Image Fire Detection designed for demanding industrial environments and modern operational resilience requirements.

By combining preventive thermal monitoring, operational visibility, industrial integration, cybersecurity, and decentralized edge-based processing, the solution helps organizations rethink how thermal-risk monitoring can support operational continuity and long-term resilience.

Rather than replacing conventional fire detection technologies, Preventive Thermal Image Fire Detection expands industrial protection strategies with an additional operational layer focused on earlier visibility, proactive intervention, and reduced downtime exposure.

The result is not simply earlier fire detection. It is earlier operational awareness, stronger resilience, and better protection for modern industrial operations.

16 Legal Disclaimer

This whitepaper is provided for informational purposes only and is intended to support discussions around preventive thermal image fire detection and industrial risk management.

The information contained herein does not constitute engineering advice, fire protection design guidance, legal advice, insurance advice, or regulatory certification recommendations. While MOBOTIX strives to provide accurate and up-to-date information, all specifications, approvals, integrations, and product capabilities may be subject to change without notice.

The suitability of any thermal image fire detection solution depends on the specific operational environment, applicable local regulations, insurance requirements, fire protection concepts, and project conditions. Organizations should consult qualified fire protection engineers, insurers, system integrators, and regulatory experts before implementing any fire detection or risk management solution.

Thermal image fire detection is intended to complement, not replace, required fire protection systems where mandated by applicable laws, standards, or regulations.

All trademarks, product names, certifications, and company names are the property of their respective owners.

© MOBOTIX AG. All rights reserved.

17 Contact information

MOBOTIX AG

Kaiserstrasse

D-67722 Langmeil

GERMANY

www.mobotix.com